

CRANE GZ1000

LIFTING CAPACITY 1000 KG

COUNTERBALANCED CRANE WITH RIGID ARM HYDRAULIC LEVER CONTROLLED FAST LIFT DOUBLE ACTION PUMP – FINE CONTROL DESCENT KNOB



Model		GZ1000
Drive		Manual
Rotation		Rigid arm
Arm lifting		Manual – double action lifting pump
Arm lowering		Manual – descent knob
Arm extension		Manual – lockable in 4 positions
Width	mm/inch.	800 / 31
Max capacity with standard arm	Kg / lbs.	1000 / 2204 * see load chart below
Max capacity with extension PZF_MBP	Kg / lbs.	450 / 992 * see load chart below
Weight of the crane (counterweight incl.)	Kg / lbs.	1190 / 2623
Battery type		Lead acid
Batteries nos.	pcs	1
Battery voltage / nominal capacity	V / Ah	12 / 80
Lifting motor	W	-
Traction motor	W	-

CRANE GZ1000 MAIN DIMENSIONS

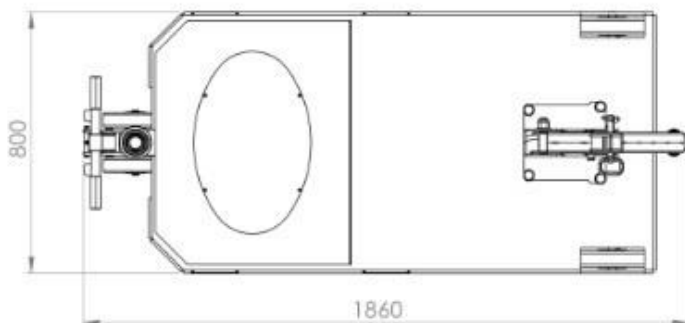
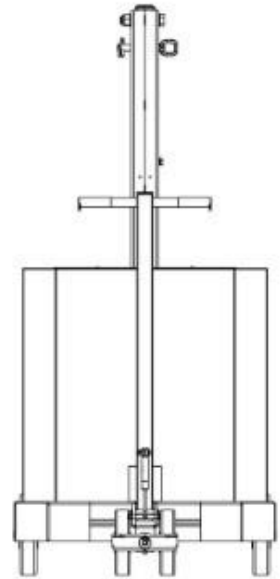
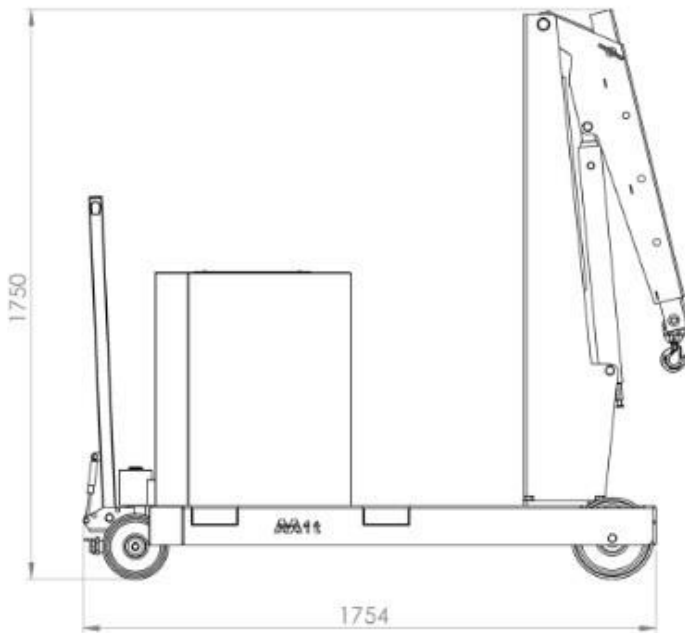

CRANE GZ1000 DETAILED DIMENSIONS WITH STANDARD ARM

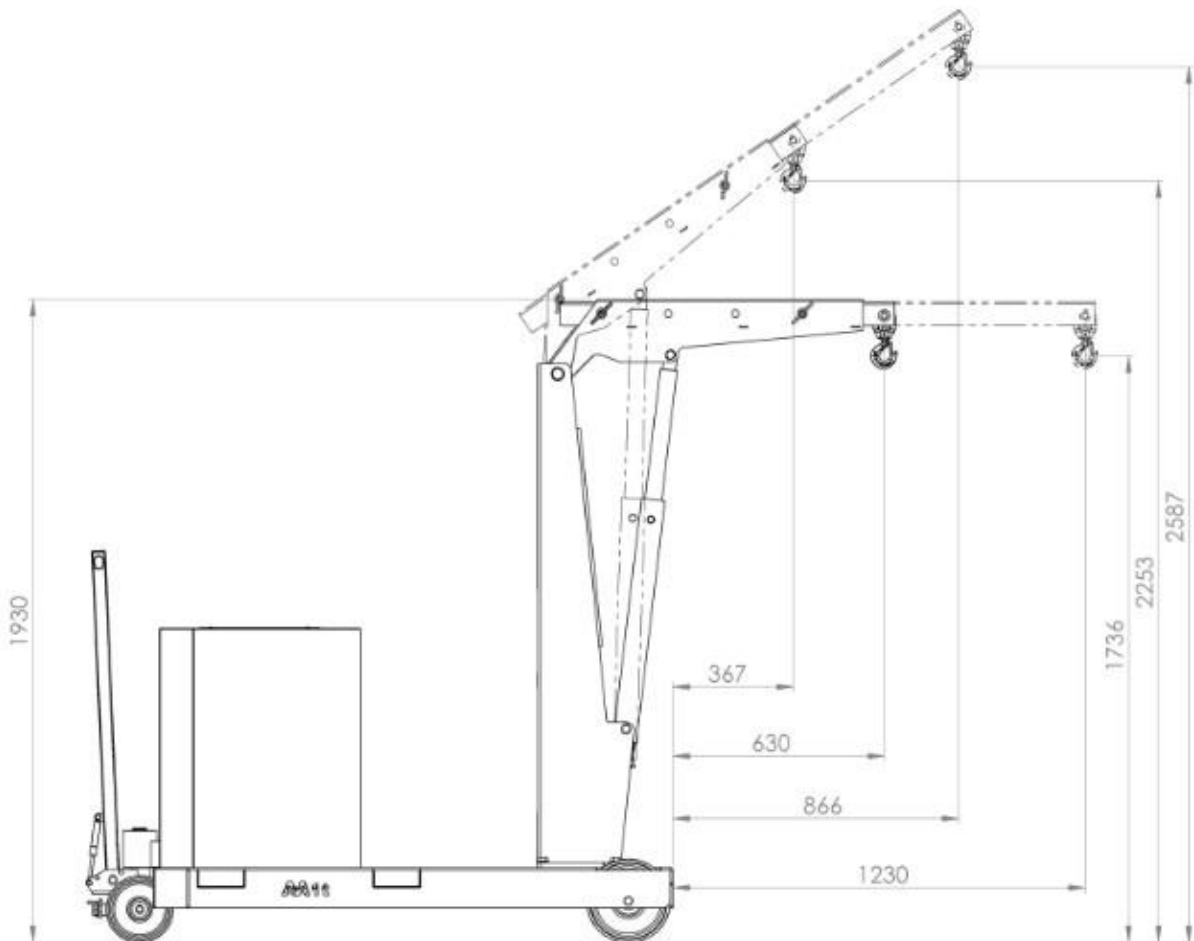

CRANE GZ1000 LOAD CHART WITH STANDARD ARM

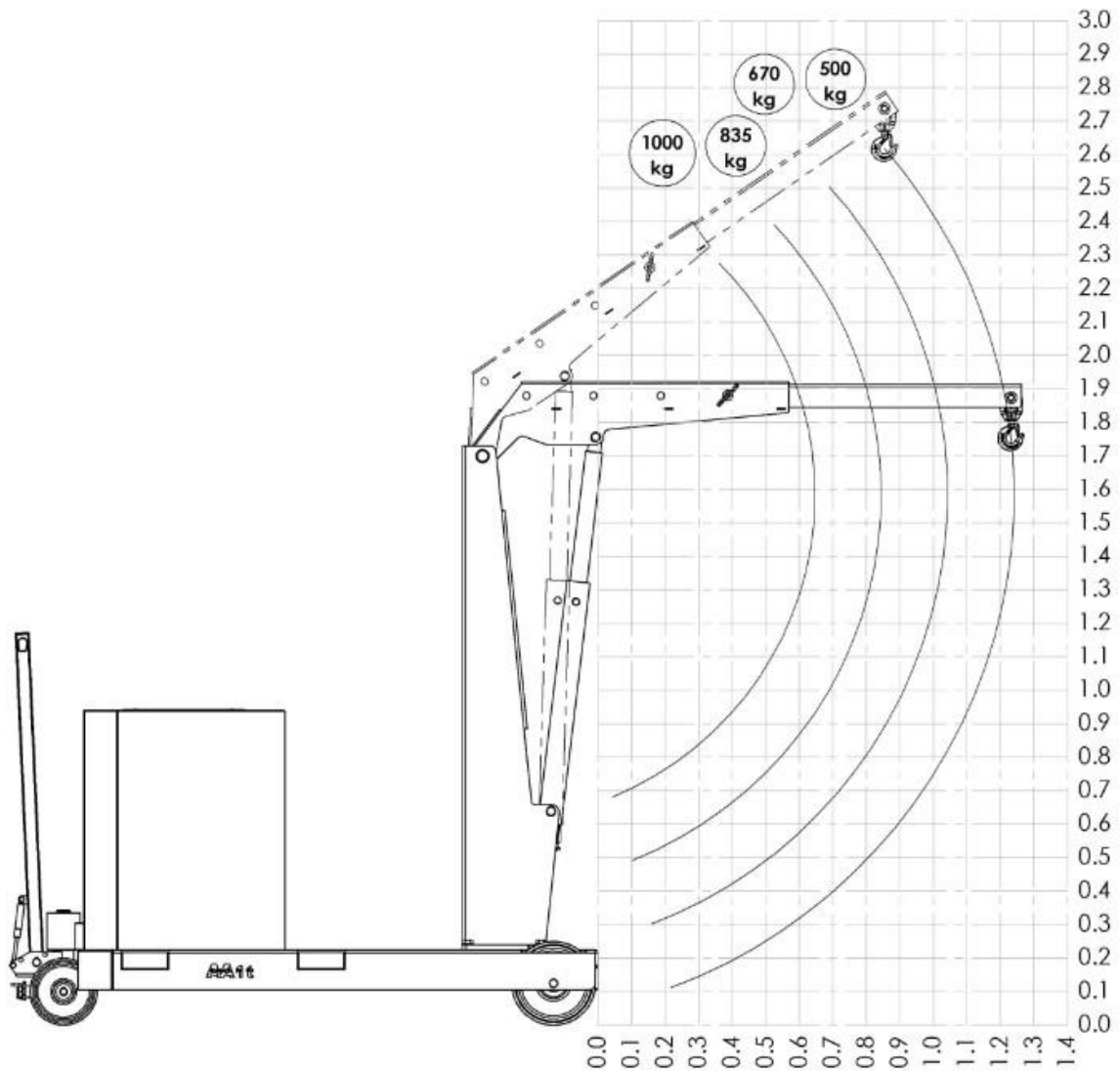

POS.	OVERHANG MM / INCH.	CAPACITY KG / LBS.
1	650 / 25	1000 / 2204
2	850 / 33	835 / 1840
3	1050 / 41	670 / 1477
4	1250 / 49	500 / 1102

CRANE GZ1000

LOAD CHART WITH OPTIONAL EXTENSION PZF_MBP

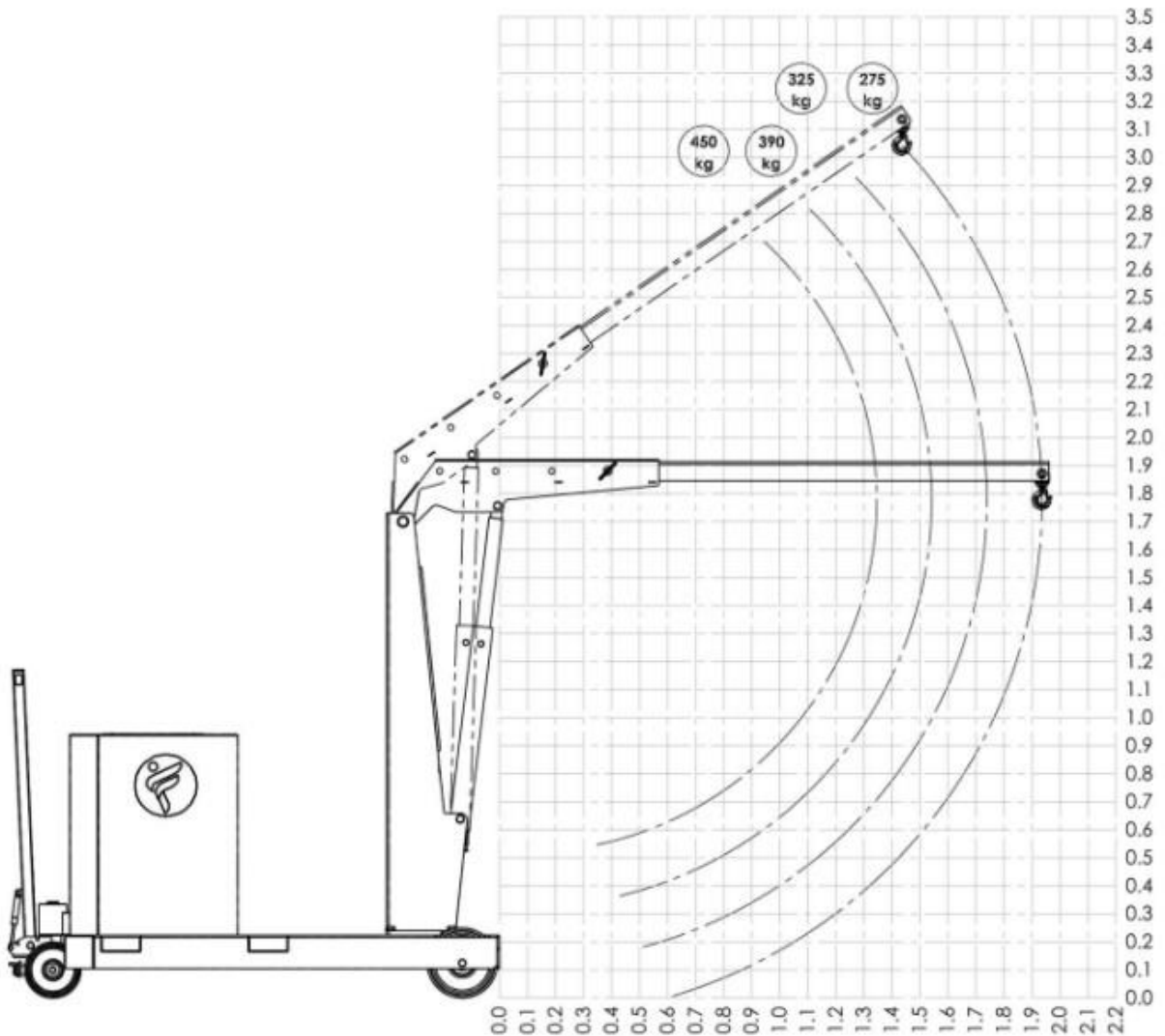

POS.	OVERHANG MM / INCH.	CAPACITY KG / LBS.
1	1400 / 55	450 / 992
2	1600 / 63	390 / 859
3	1800 / 70	325 / 716
4	2000 / 78	275 / 606

CRANE GZ1000B
LIFTING CAPACITY 1000 KG
COUNTERBALANCED CRANE WITH RIGID ARM
ELECTRIC LIFT & LOWER AT SINGLE SPEED



Model		GZ1000B
Drive		Manual
Rotation		Rigid arm
Arm lifting		Electric – push button pendant station
Arm lowering		Electric – push button pendant station
Arm extension		Manual – lockable in 4 positions
Width	mm/inch.	800 / 31
Max capacity with standard arm	Kg / lbs.	1000 / 2204 * see load chart below
Max capacity with extension PZF_MBP	Kg / lbs.	450 / 992 * see load chart below
Weight of the crane (counterweight incl.)	Kg / lbs.	1190 / 2623
Battery type		Lead acid
Batteries nos.	pcs	1
Battery voltage / nominal capacity	V / Ah	12 / 80
Lifting motor	W	-
Traction motor	W	-

CRANE GZ1000B MAIN DIMENSIONS

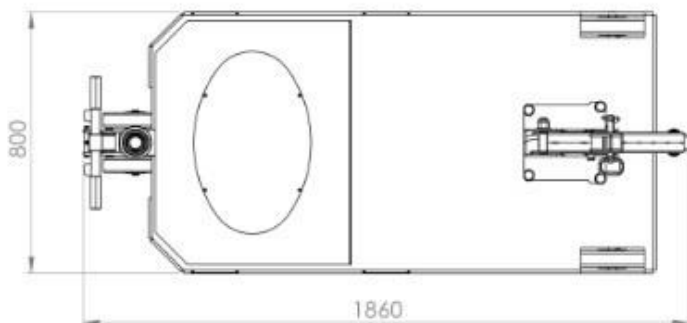
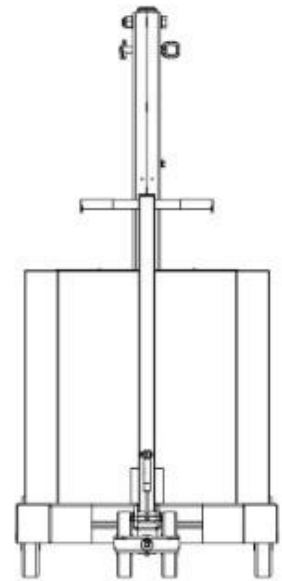
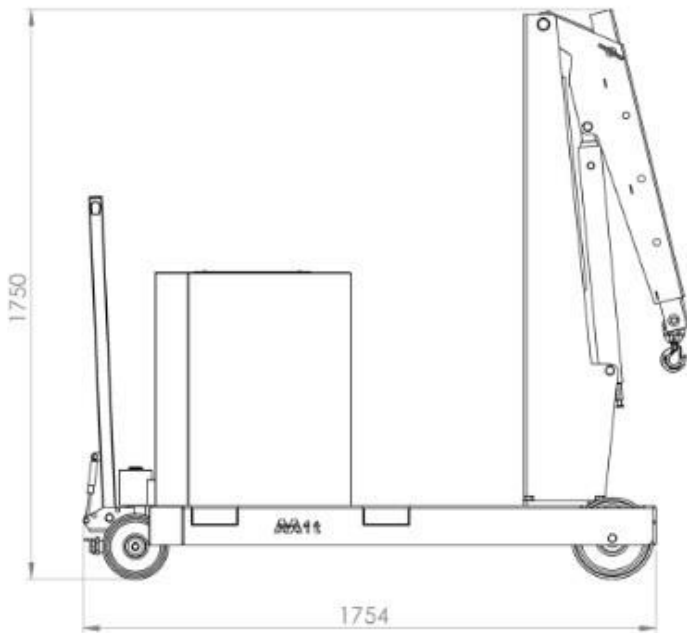

CRANE GZ1000B DETAILED DIMENSIONS WITH STANDARD ARM

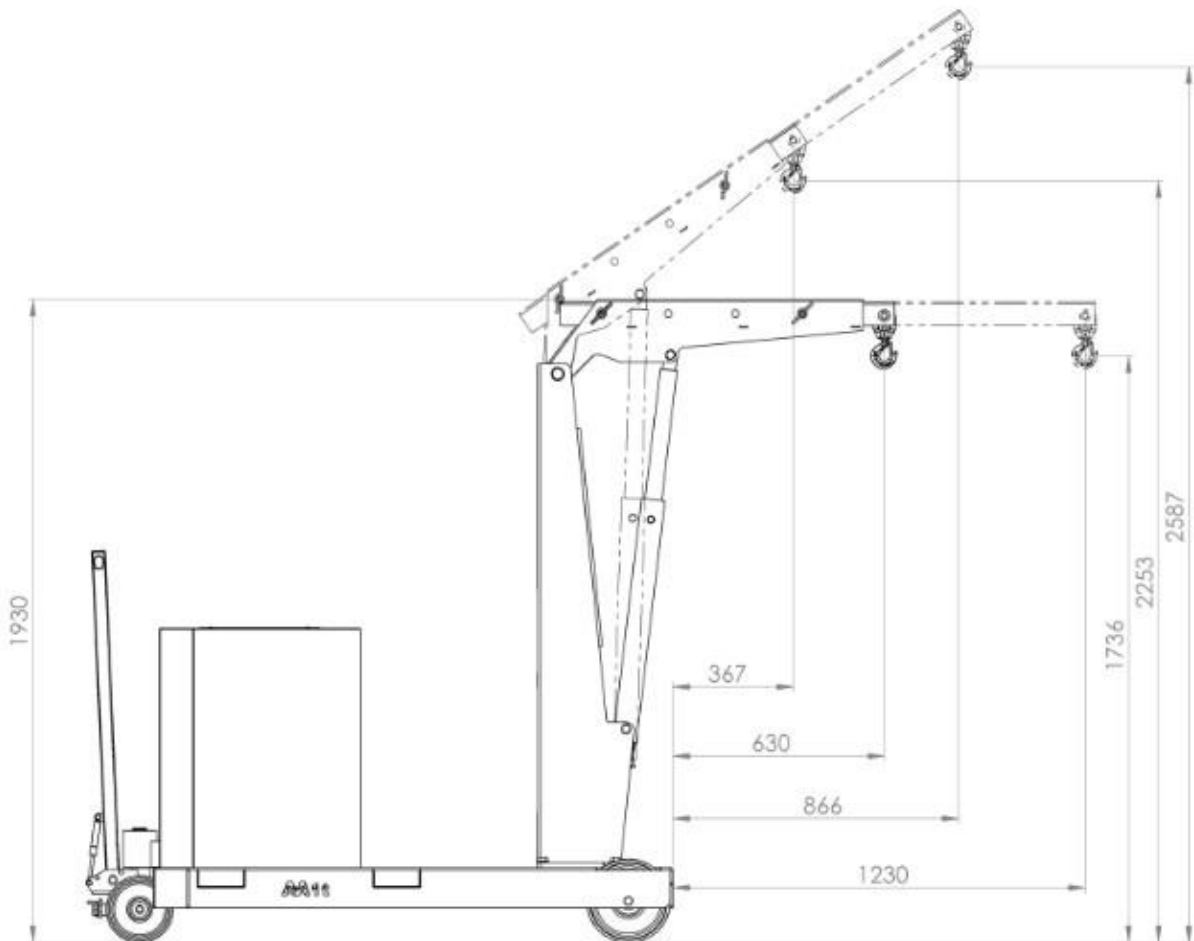

CRANE GZ1000B LOAD CHART WITH STANDARD ARM

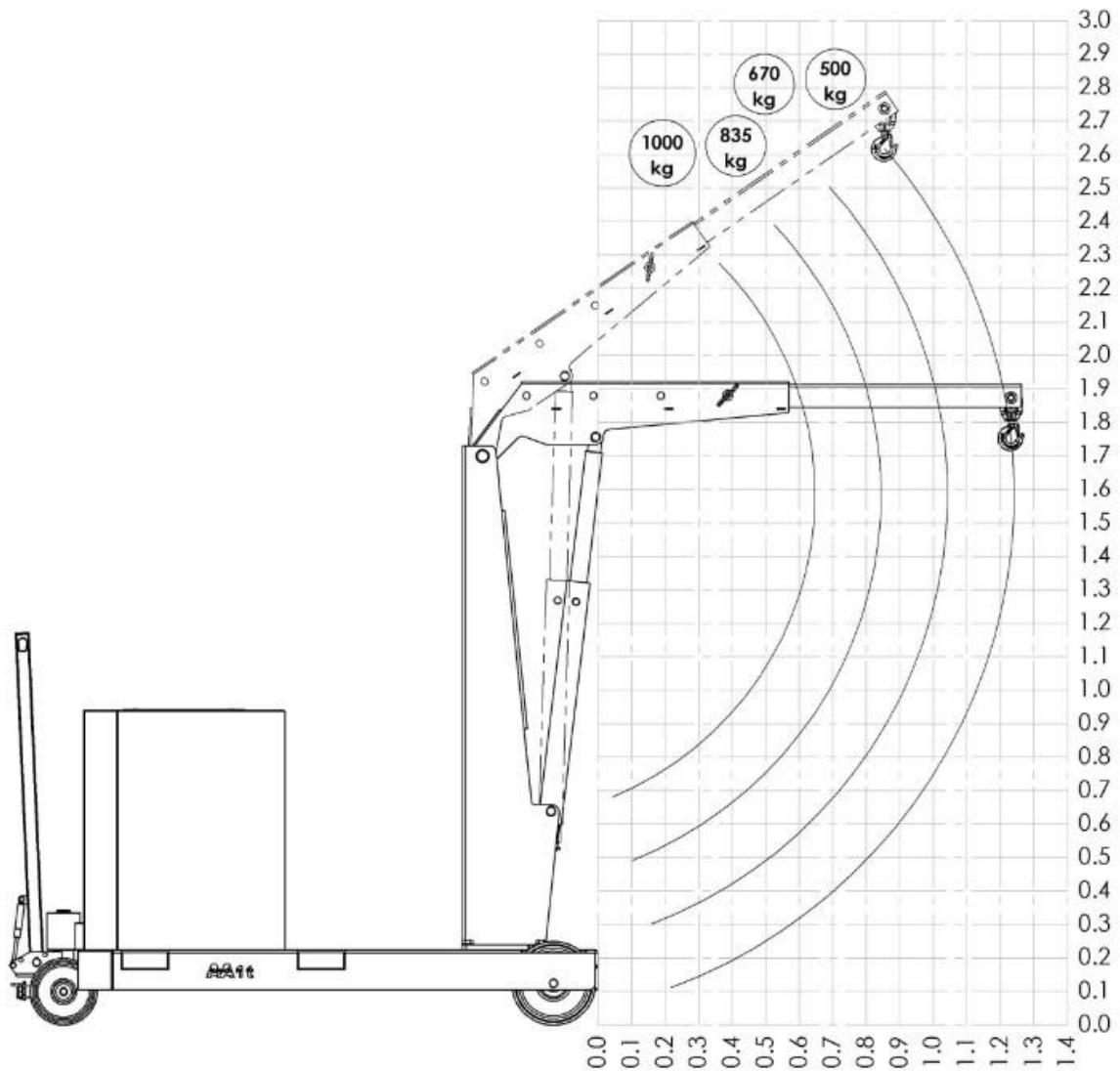

POS.	OVERHANG MM / INCH.	CAPACITY KG / LBS.
1	650 / 25	1000 / 2204
2	850 / 33	835 / 1840
3	1050 / 41	670 / 1477
4	1250 / 49	500 / 1102

CRANE GZ1000B

LOAD CHART WITH OPTIONAL EXTENSION PZF_MBP

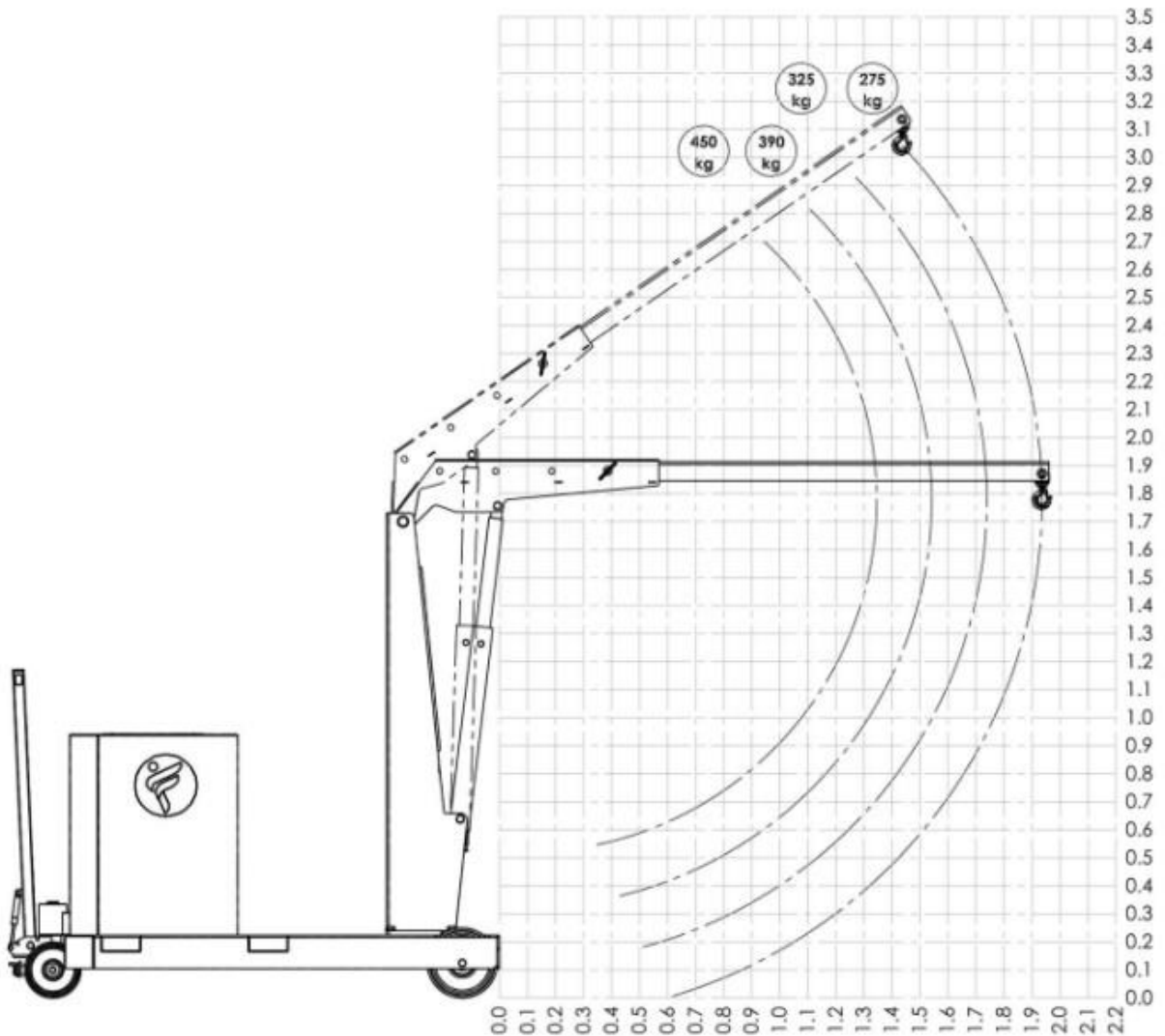

POS.	OVERHANG MM / INCH.	CAPACITY KG / LBS.
1	1400 / 55	450 / 992
2	1600 / 63	390 / 859
3	1800 / 70	325 / 716
4	2000 / 78	275 / 606

CRANE GZ1000BP

LIFTING CAPACITY 1000 KG

COUNTERBALANCED CRANE WITH RIGID ARM ELECTRIC LIFT AT SINGLE SPEED AND ELECTRIC LOWER AT ADJUSTABLE SPEED



Model		GZ1000BP
Drive		Manual
Rotation		Rigid arm
Arm lifting		Electric – push button pendant station
Arm lowering		Electric – push button pendant station
Arm extension		Manual - lockable in 4 positions
Width	mm/inch.	800 / 31
Max capacity with standard arm	Kg / lbs.	1000 / 2204 * see load chart below
Max capacity with extension PZF_MBP	Kg / lbs.	450 / 992 * see load chart below
Weight of the crane (counterweight incl.)	Kg / lbs.	1190 / 2623
Battery type		Lead acid
Batteries nos.	pcs	1
Battery voltage / nominal capacity	V / Ah	12 / 80
Lifting motor	W	-
Traction motor	W	-

CRANE GZ1000BP MAIN DIMENSIONS

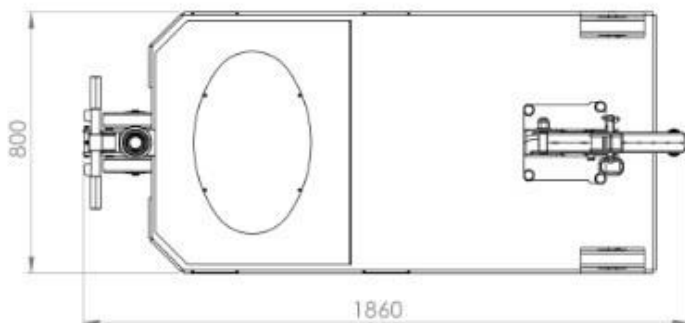
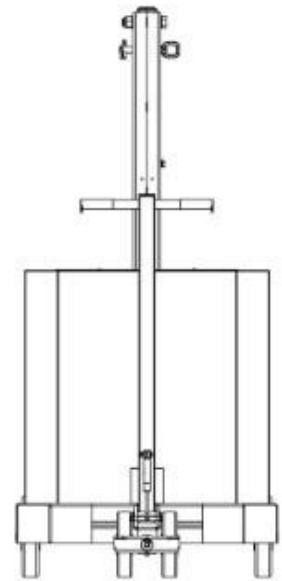
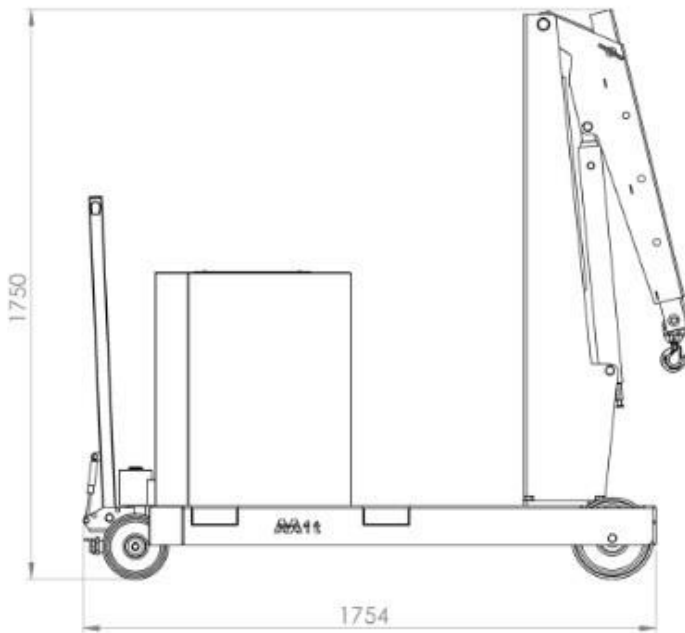

CRANE GZ1000BP DETAILED DIMENSIONS WITH STANDARD ARM

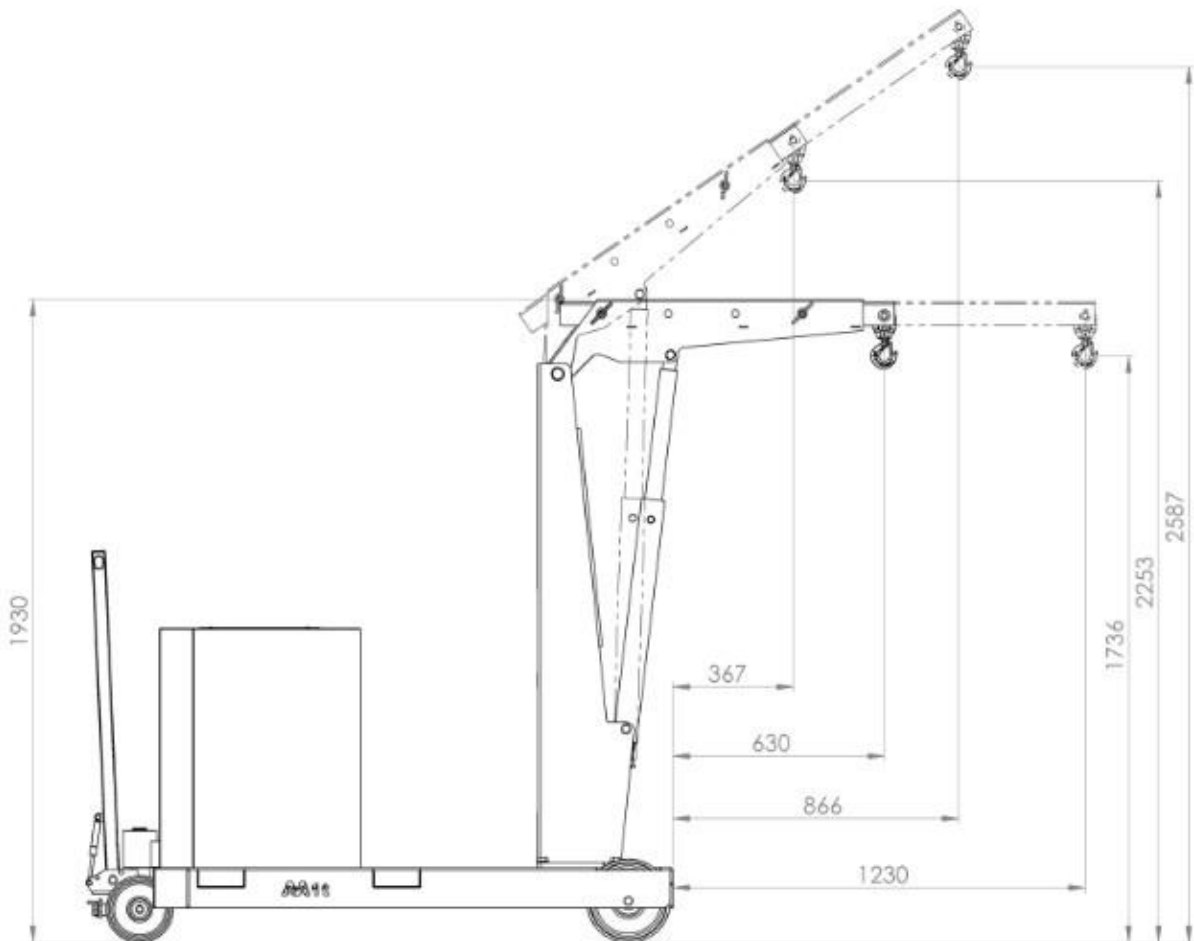

CRANE GZ1000BP LOAD CHART WITH STANDARD ARM

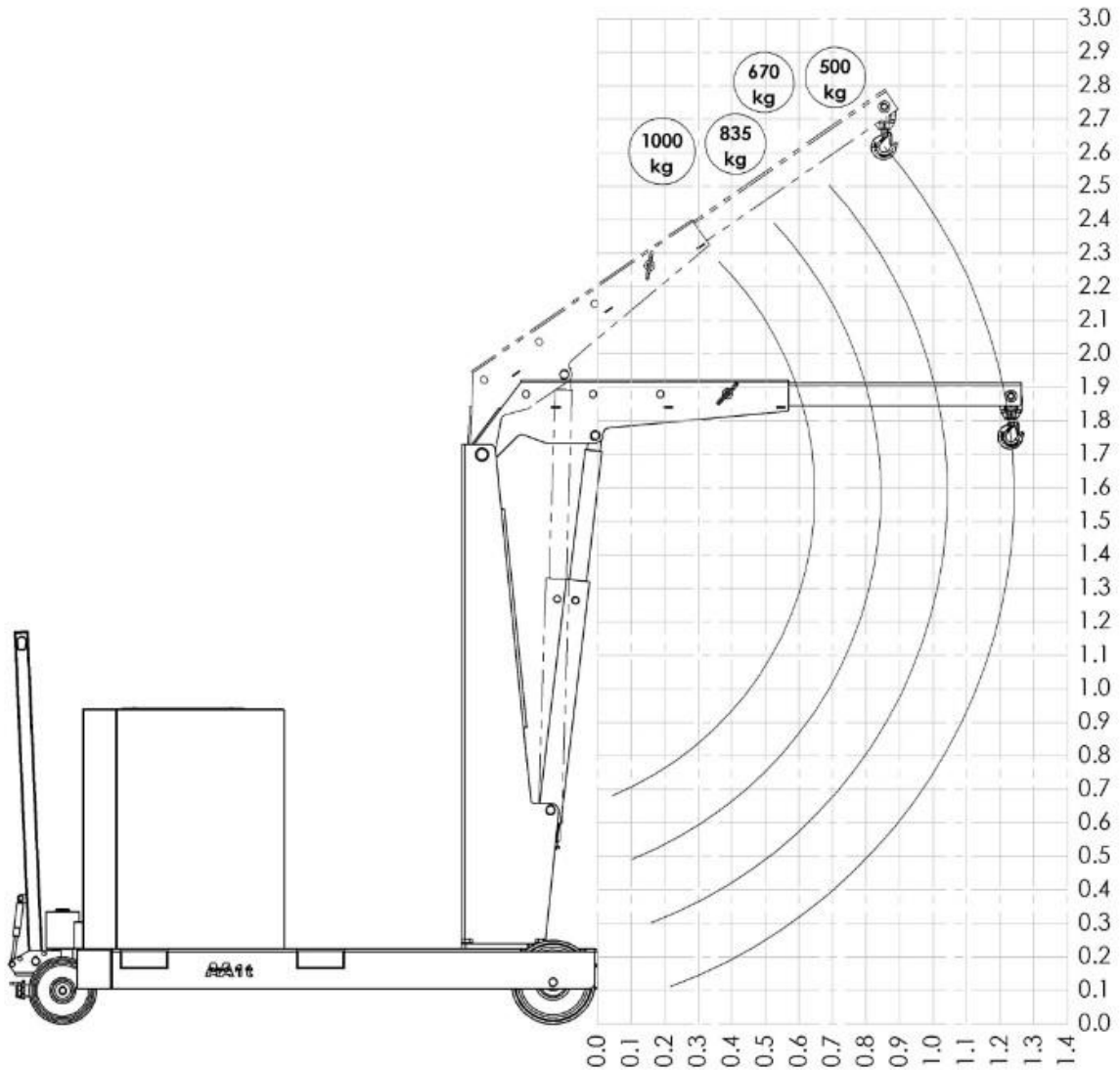

POS.	OVERHANG MM / INCH.	CAPACITY KG / LBS.
1	650 / 25	1000 / 2204
2	850 / 33	835 / 1840
3	1050 / 41	670 / 1477
4	1250 / 49	500 / 1102

CRANE GZ1000BP

LOAD CHART WITH OPTIONAL EXTENSION PZF_MBP

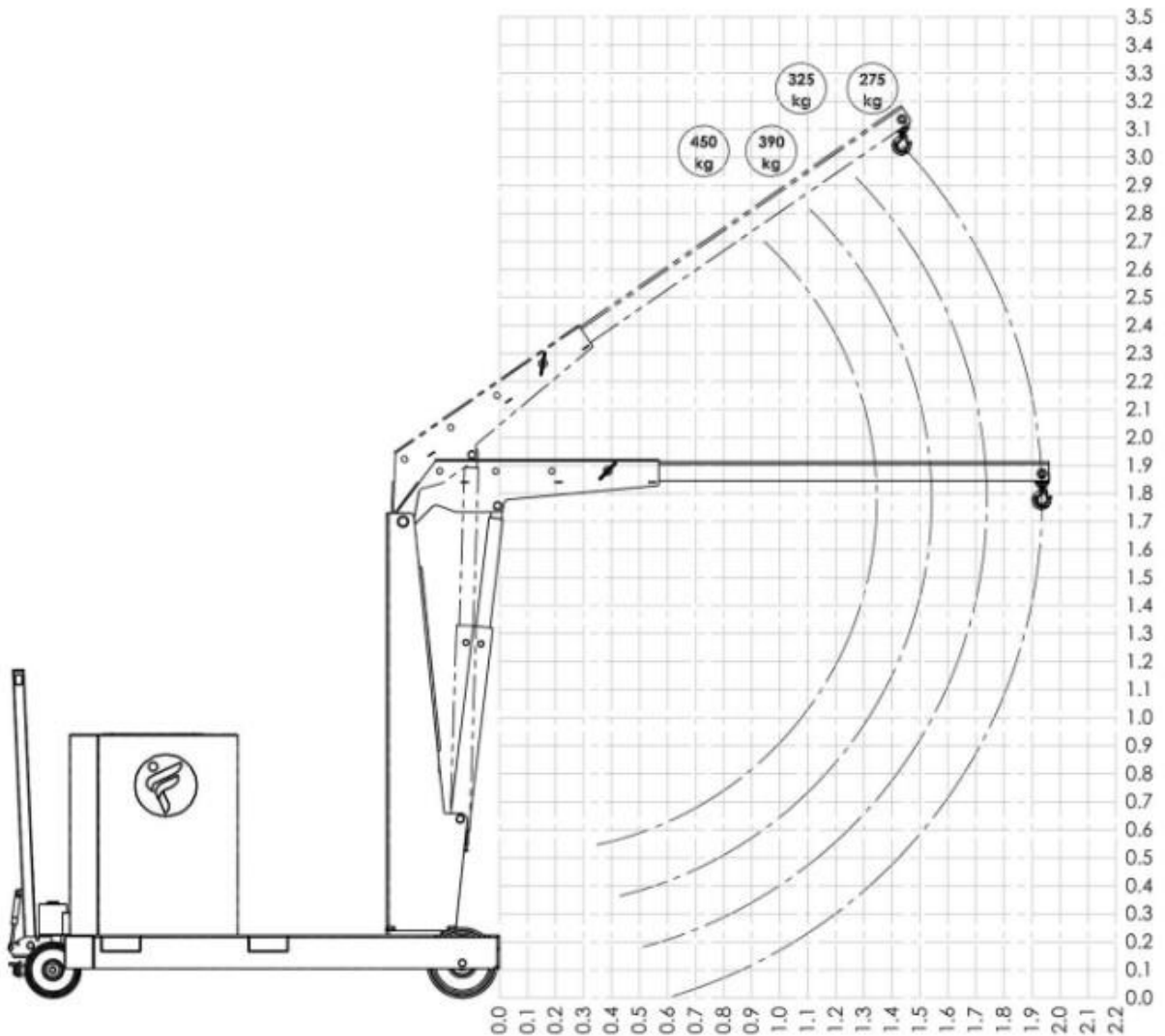

POS.	OVERHANG MM / INCH.	CAPACITY KG / LBS.
1	1400 / 55	450 / 992
2	1600 / 63	390 / 859
3	1800 / 70	325 / 716
4	2000 / 78	275 / 606

CRANE GZ1000BSE

LIFTING CAPACITY 1000 KG

COUNTERBALANCED CRANE WITH RIGID ARM ELECTRIC LIFT /LOWER/EXTEND/RETRACT THROUGH
4-WAY CONTROL LEVERS AT ADJUSTABLE SPEED



Model		GZ1000BSE
Drive		Manual
Rotation		Rigid arm
Arm lifting		Electric – control lever
Arm lowering		Electric – control lever
Arm extension		Electric – control lever
Width	mm/inch.	800 / 31
Max capacity with standard arm	Kg / lbs.	1000 / 2204 * see load chart below
Max capacity with extension PZF_SE	Kg / lbs.	200 / 440 * see load chart below
Weight of the crane (counterweight incl.)	Kg / lbs.	1195 / 2634
Battery type		Lead acid
Batteries nos.	pcs	1
Battery voltage / nominal capacity	V / Ah	12 / 80
Lifting motor	W	-
Traction motor	W	-

CRANE GZ1000BSE MAIN DIMENSIONS

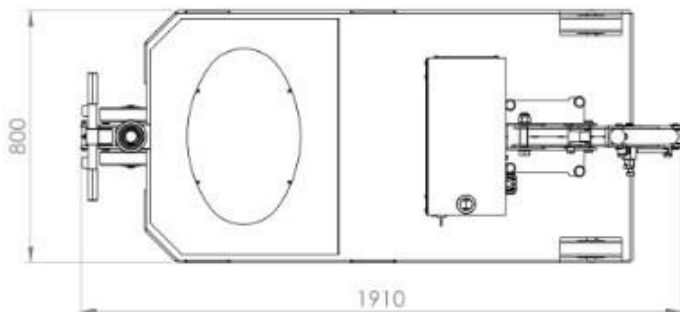
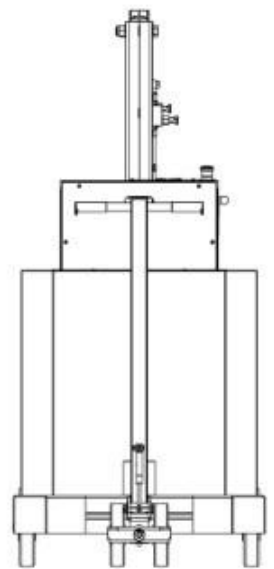
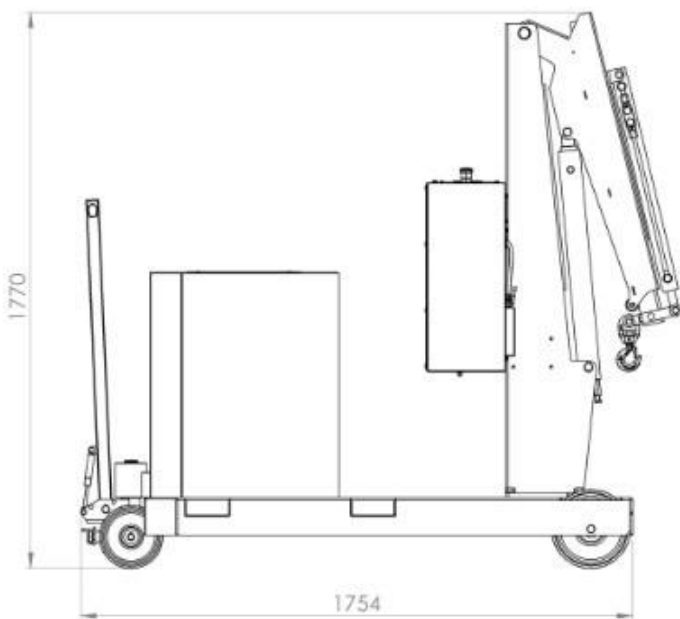

CRANE GZ1000BSE DETAILED DIMENSIONS WITH STANDARD ARM

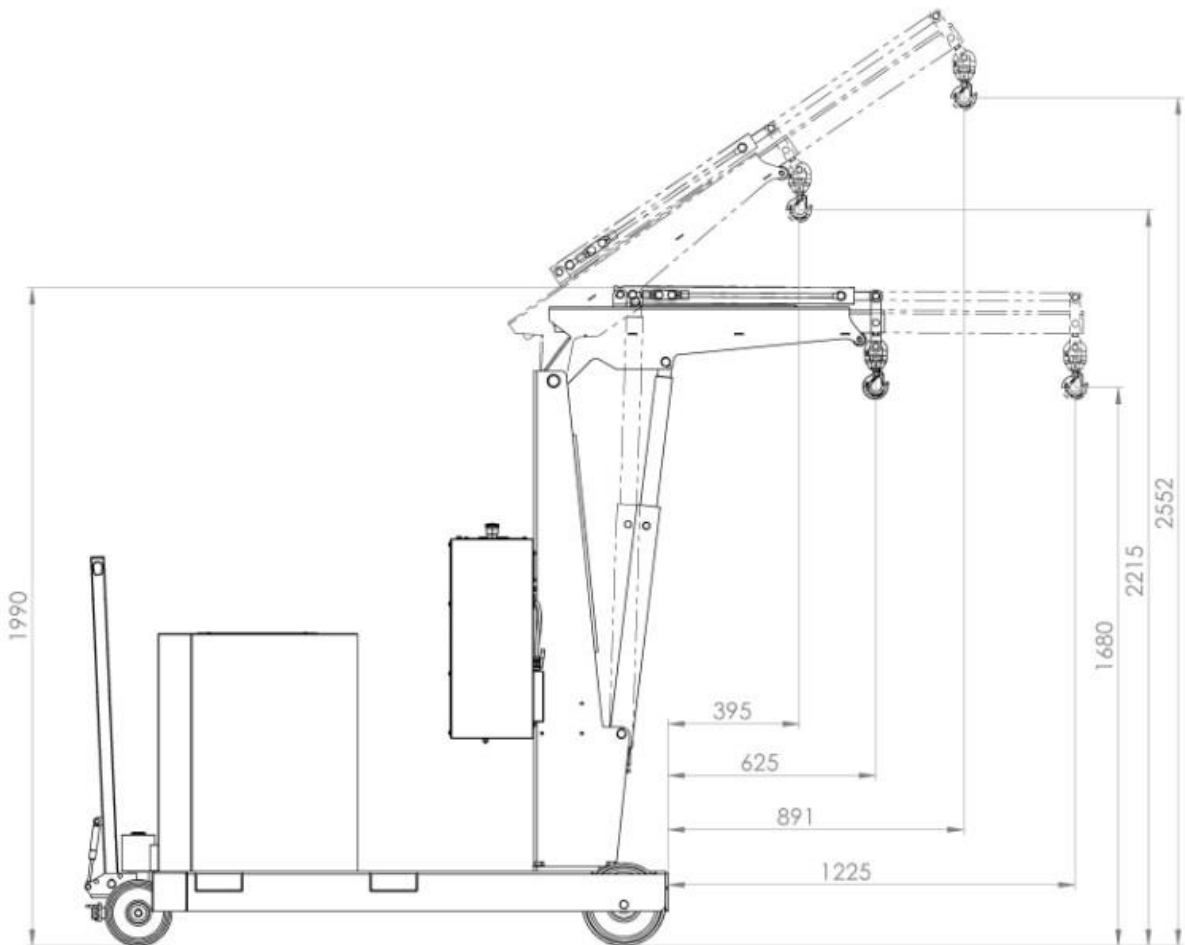

CRANE GZ1000BSE LOAD CHART WITH STANDARD ARM

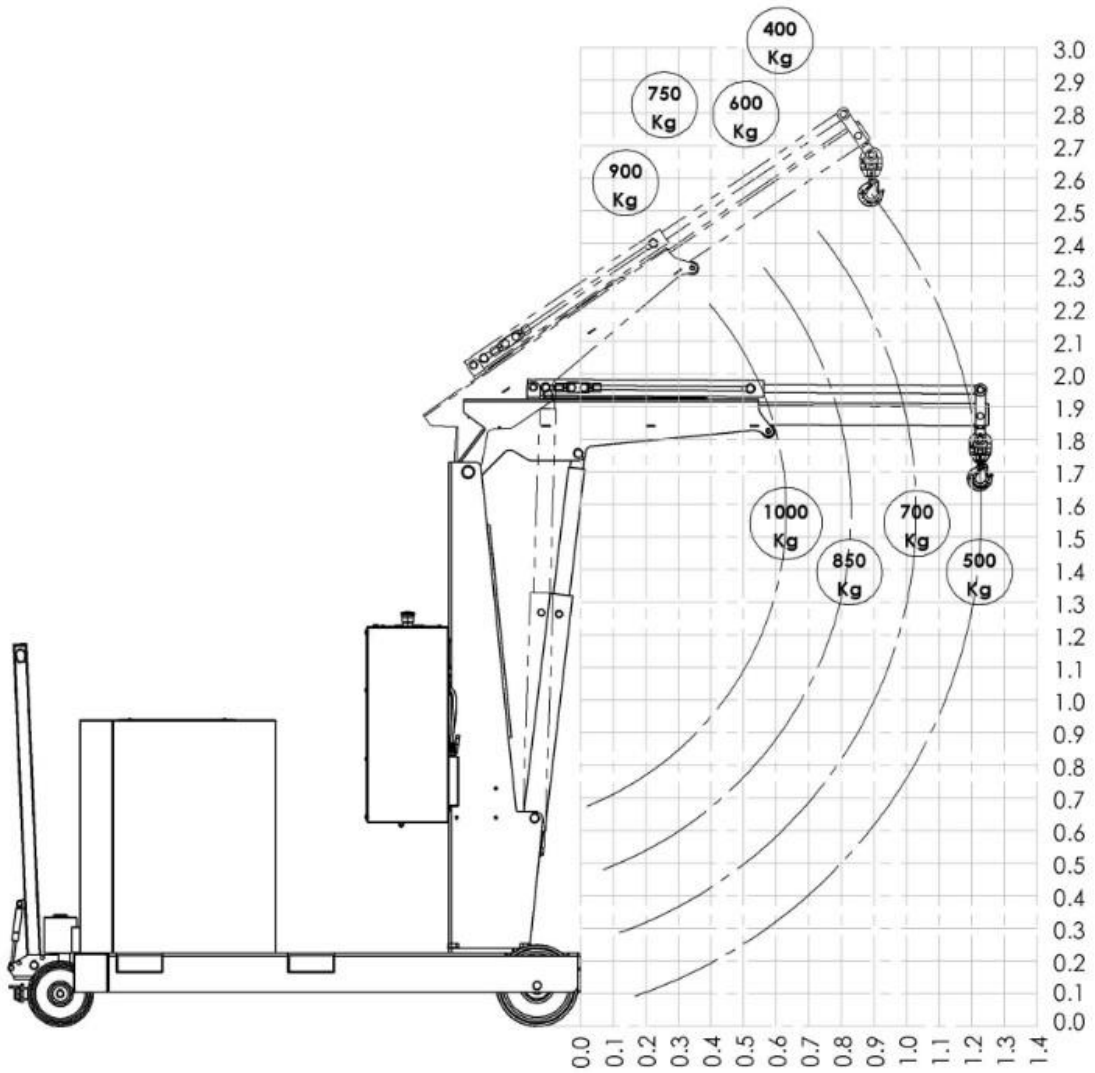

CRANE GZ1000BSE LOAD CHART WITH OPTIONAL EXTENSION PZF_SE

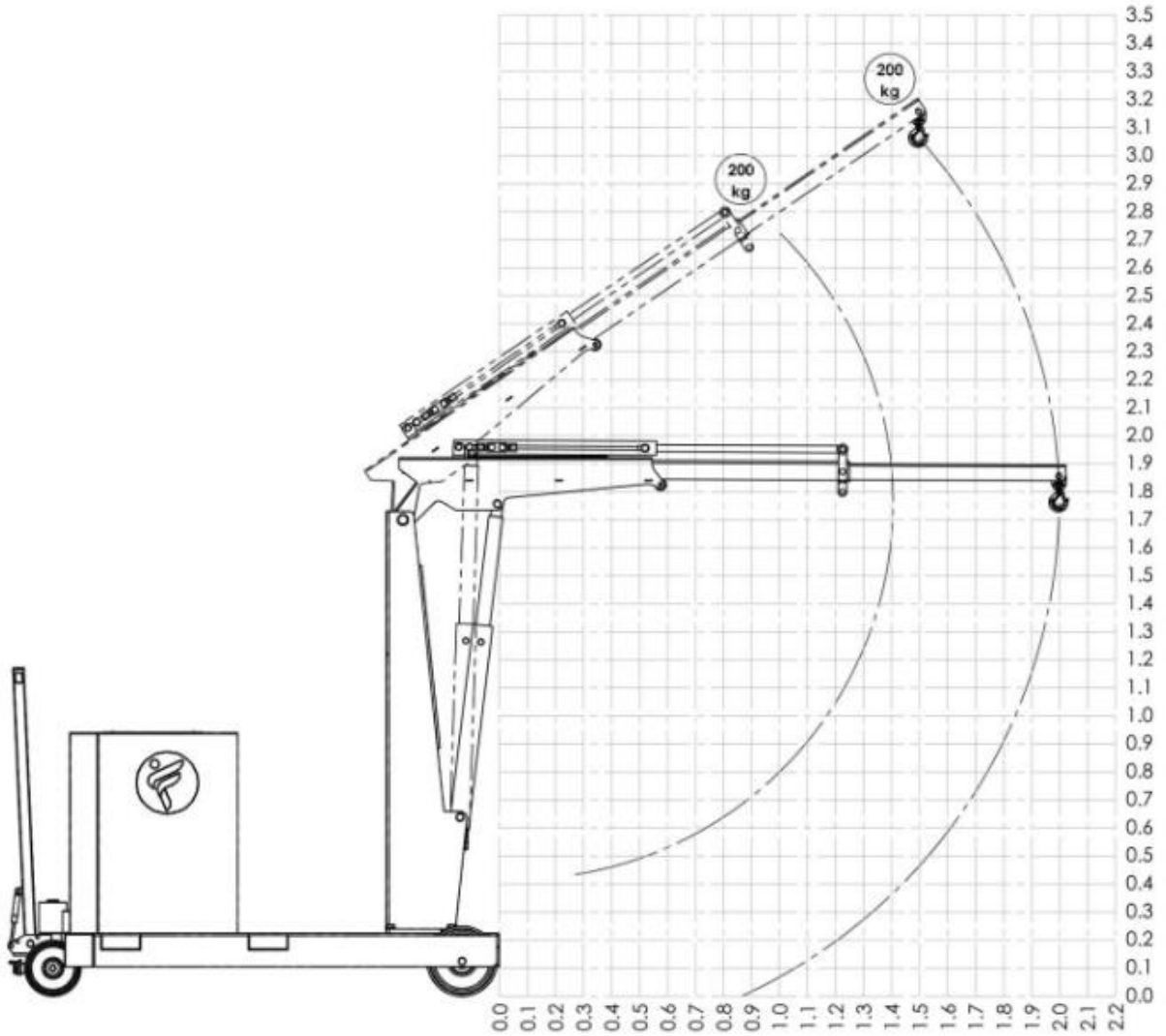

CRANE GZ1000BSER
LIFTING CAPACITY 1000 KG
COUNTERBALANCED CRANE WITH RIGID ARM
ELECTRIC LIFT/LOWER/EXTEND/RETRACT THROUGH PUSH BUTTON REMOTE CONTROL
AT ADJUSTABLE SPEED



Model		GZ1000BSER
Drive		Manual
Rotation		Rigid arm
Arm lifting		Electric – remote control
Arm lowering		Electric – remote control
Arm extension		Electric – remote control
Width	mm/inch.	800 / 31
Max capacity with standard arm	Kg / lbs.	1000 / 2204 * see load chart below
Max capacity with extension PZF_SE	Kg / lbs.	200 / 440 * see load chart below
Weight of the crane (counterweight incl.)	Kg / lbs.	1195 / 2634
Battery type		Lead acid
Batteries nos.	pcs	1
Battery voltage / nominal capacity	V / Ah	12 / 80
Lifting motor	W	-
Traction motor	W	-

CRANE GZ1000BSER MAIN DIMENSIONS

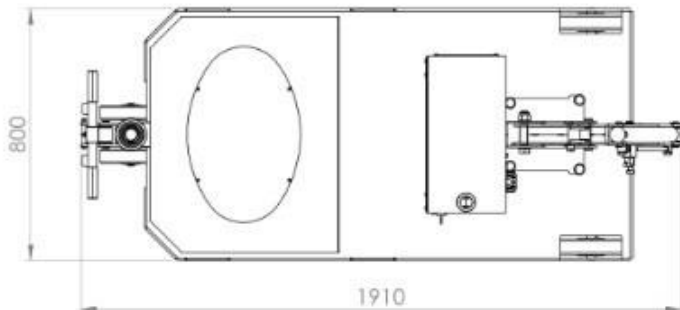
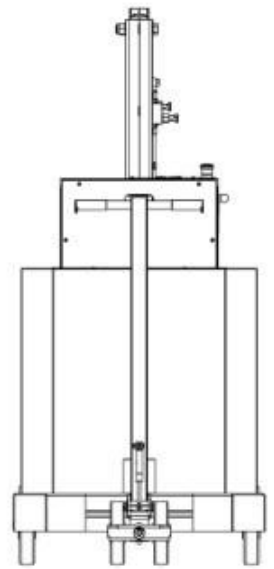
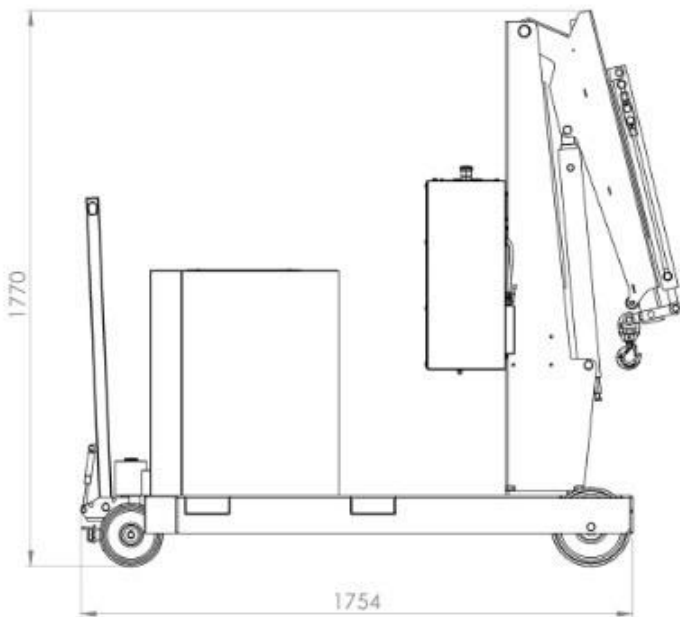

CRANE GZ1000BSER DETAILED DIMENSIONS WITH STANDARD ARM

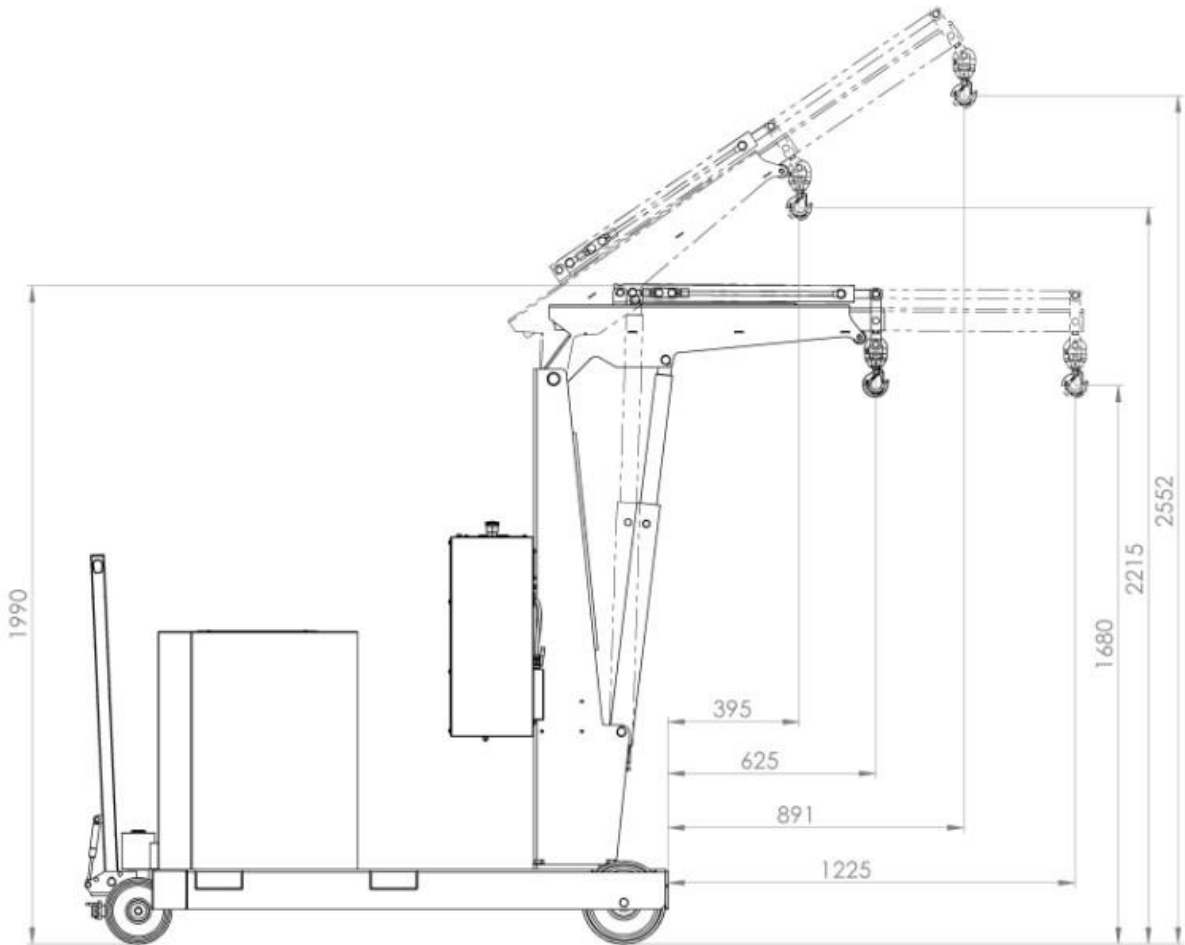

CRANE GZ1000BSER LOAD CHART WITH STANDARD ARM

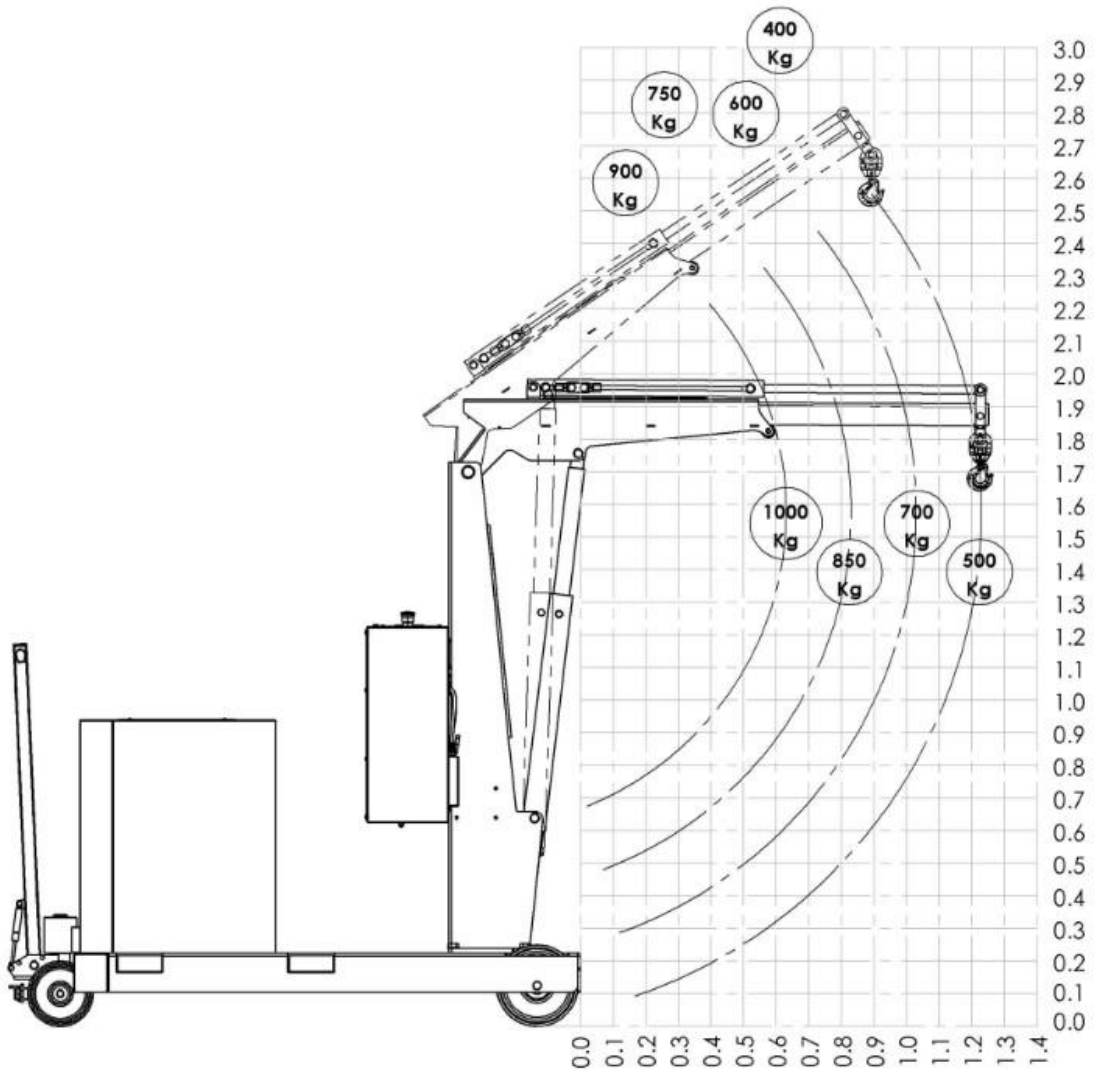

CRANE GZ1000BSER LOAD CHART WITH OPTIONAL EXTENSION PZF_SE

