

CRANE FLEX G1000DBL

LIFTING CAPACITY 1000 KG

MOTORISED COUNTERBALANCED SWIVEL CRANE

ELECTRIC LIFT/LOWER/EXTEND/RETRACT/ROTATION THROUGH CONTROL LEVERS
AT ADJUSTABLE SPEED



Model		FLEX G1000DBL
Drive		Electric
Rotation		220° electric controlled
Arm lifting		Electric – control lever
Arm lowering		Electric – control lever
Arm extension		Electric – control lever
Width with arm not rotated	mm/inch.	990 / 39
Width with arm rotated at 90°	mm/inch.	1120 / 44
Width with arm rotated at 90° and upgrade to optional compact ballast	mm/inch.	990 / 39 * see drawing below
Max capacity with standard double boom	Kg / lbs.	1000 / 2204 * see load chart below
Weight of the crane (counterweight incl.)	Kg / lbs.	1580 / 3483
Battery type standard		Maintenance free AGM
Batteries nos.	pcs	2
Battery voltage / nominal capacity	V / Ah	12 / 120
Lifting motor	W	800
Traction motor	W	1000

CRANE FLEX G1000DBL MAIN DIMENSIONS

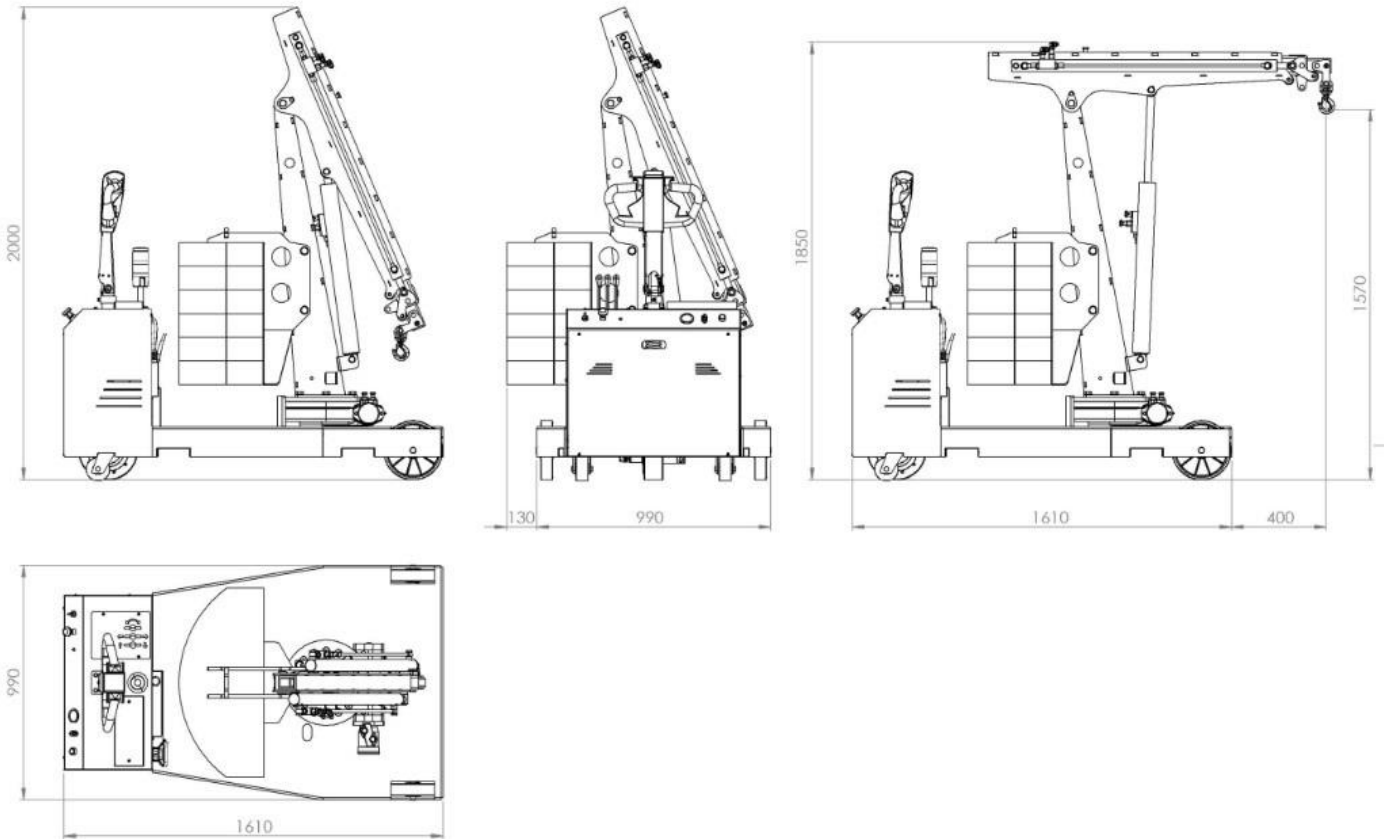

CRANE FLEX G1000DBL WIDTH WITH COMPACT BALLAST PB_FLEX G1000DB

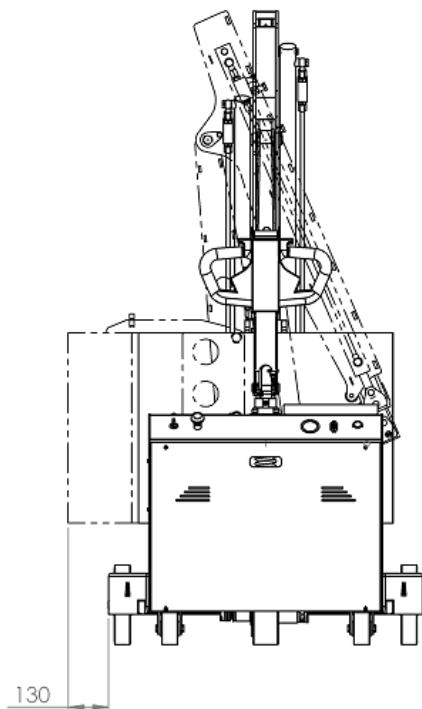
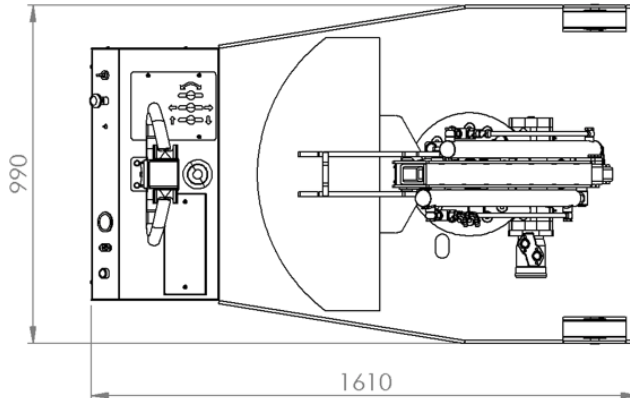

WITH STANDARD BALLAST:
WHEN THE ARM IS ROTATED AT 90°
THE BALLAST **EXCEEDS** THE CRANE
WIDTH BY 130 MM

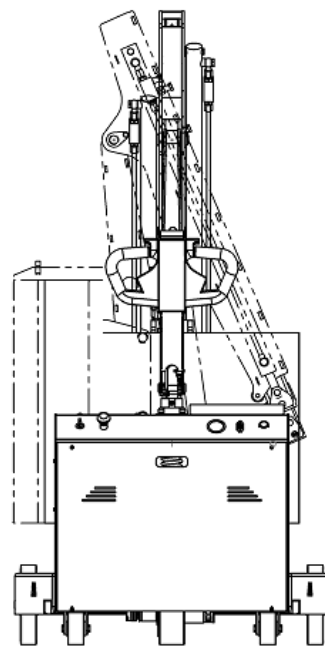

**UPGRADE TO COMPACT BALLAST
(CODE PB_FLEX G1000DB)**
WHEN THE ARM IS ROTATED AT 90° THE
BALLAST **DOESN'T EXCEED** THE CRANE
WIDTH OF 990 MM

CRANE FLEX G1000DBL DETAILED DIMENSIONS WITH STANDARD ELECTRIC TELESCOPIC DOUBLE BOOM FULLY RETRACTED

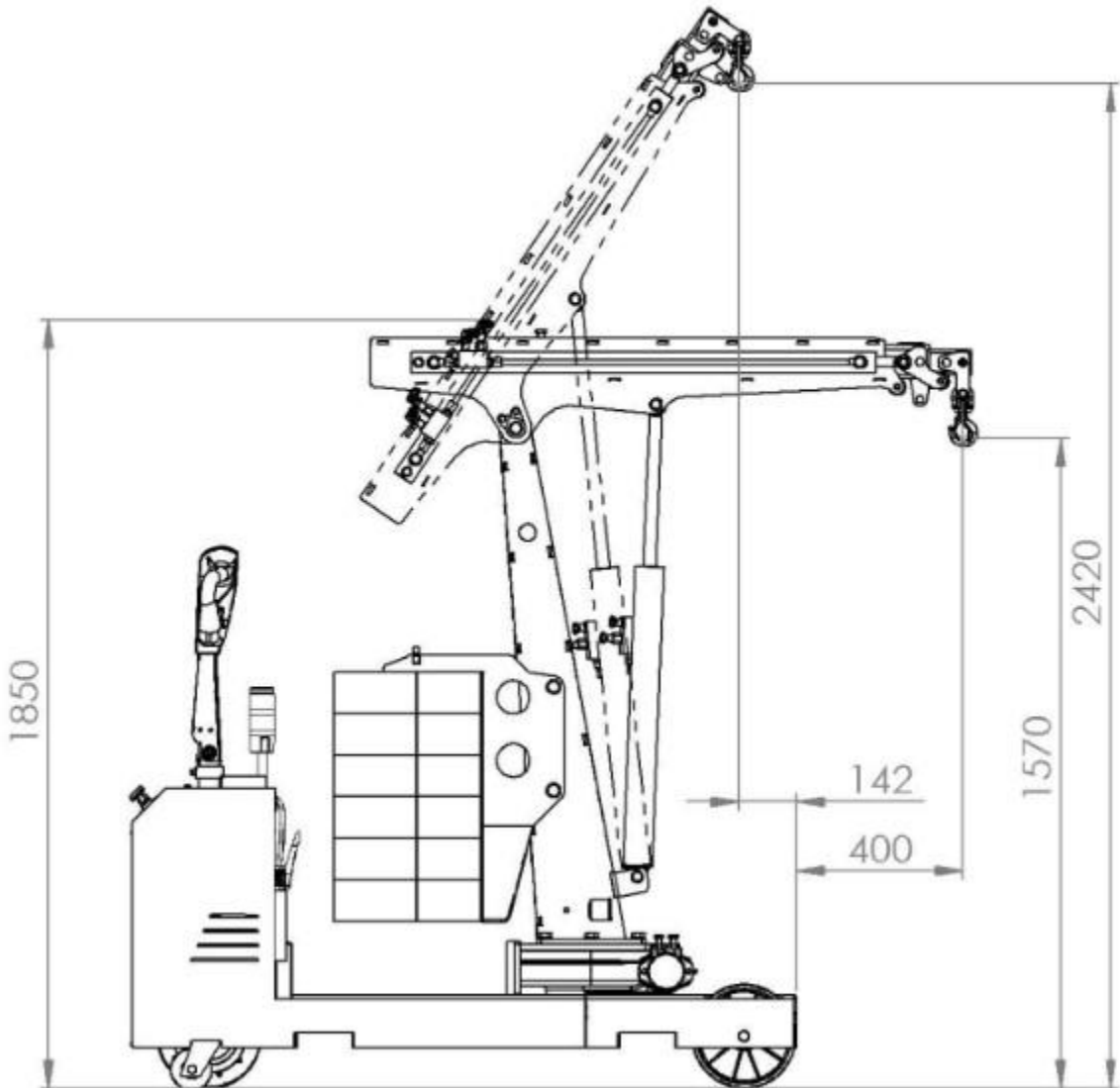

CRANE FLEX G1000DBL DETAILED DIMENSIONS WITH STANDARD ELECTRIC TELESCOPIC DOUBLE BOOM FULLY EXTENDED

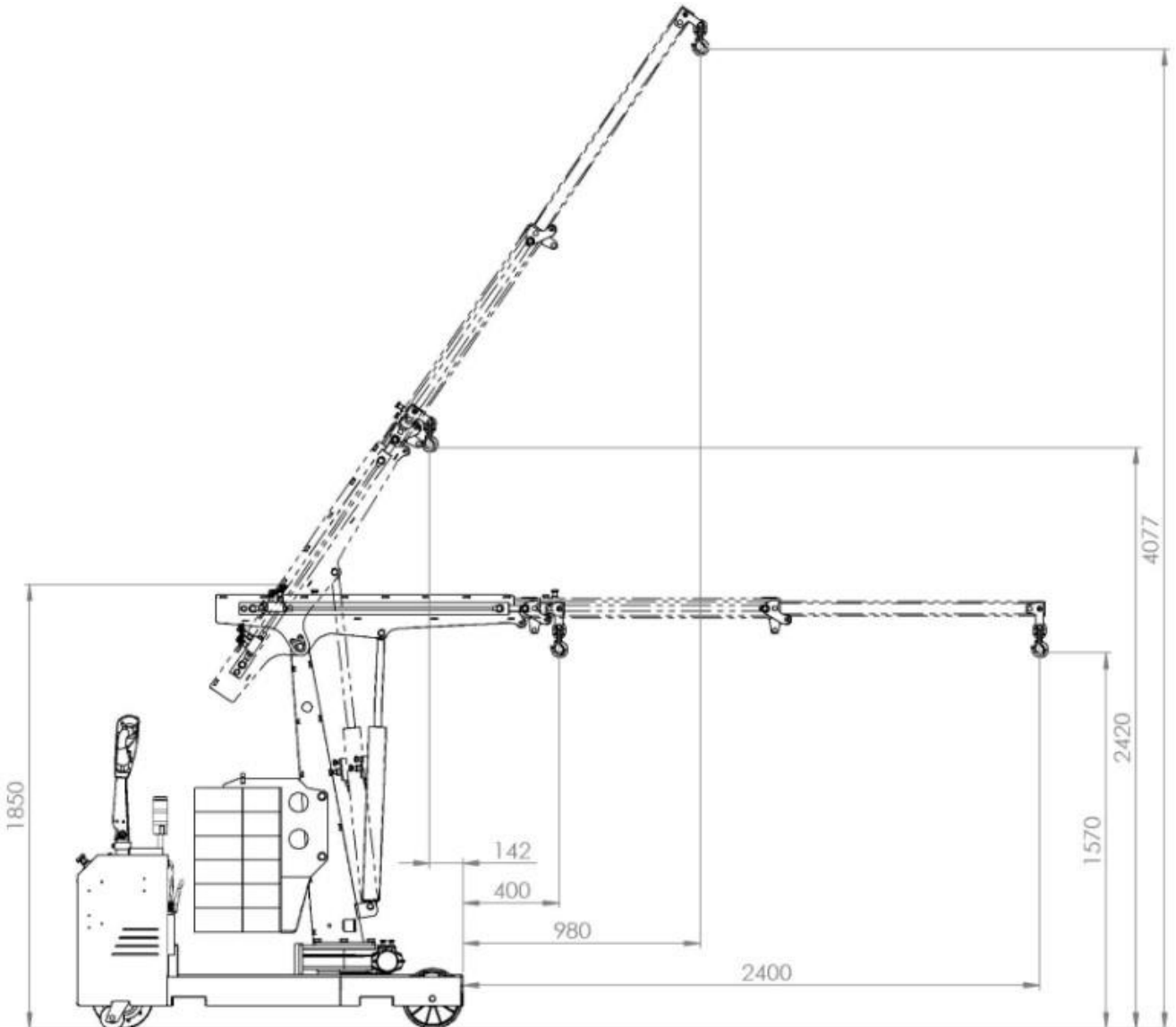

CRANE FLEX G1000DBL MAIN DIMENSIONS

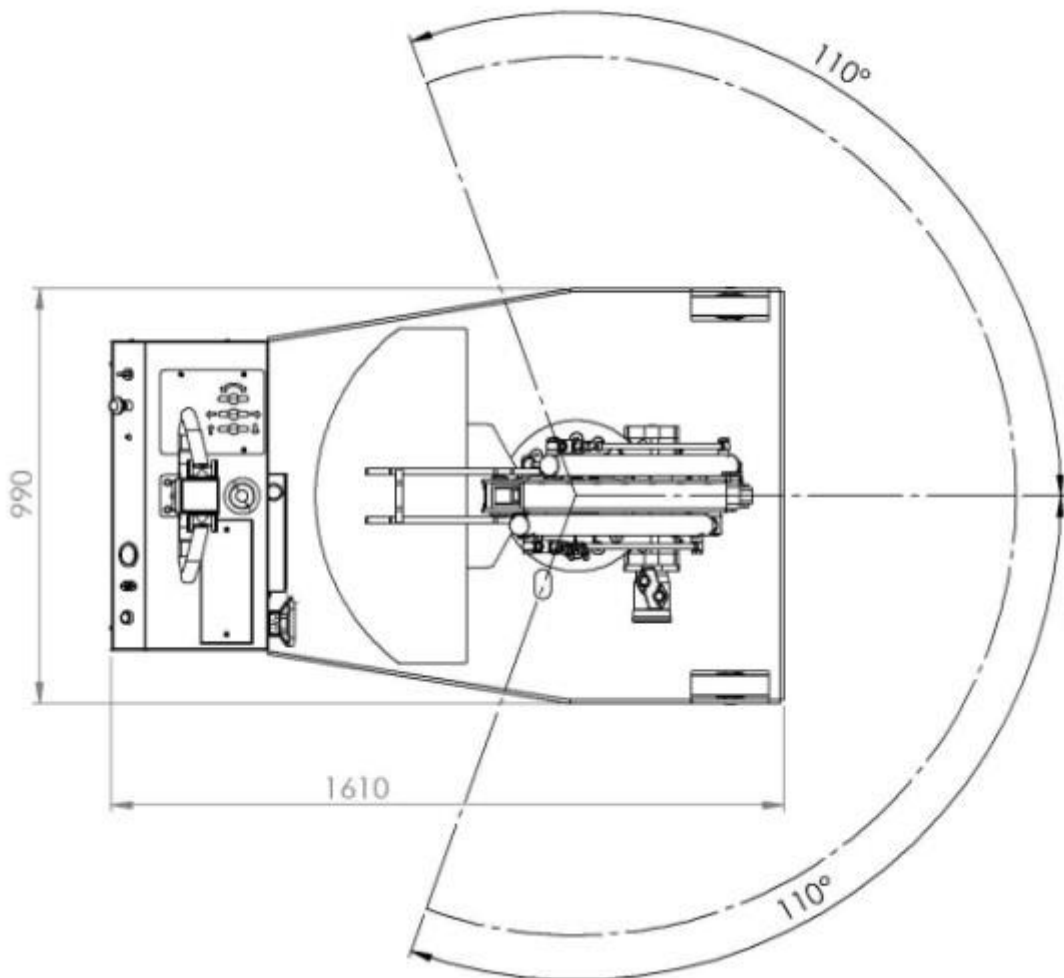

CRANE FLEX G1000DBL LOAD CHART WITH STANDARD ELECTRIC TELESCOPIC DOUBLE BOOM

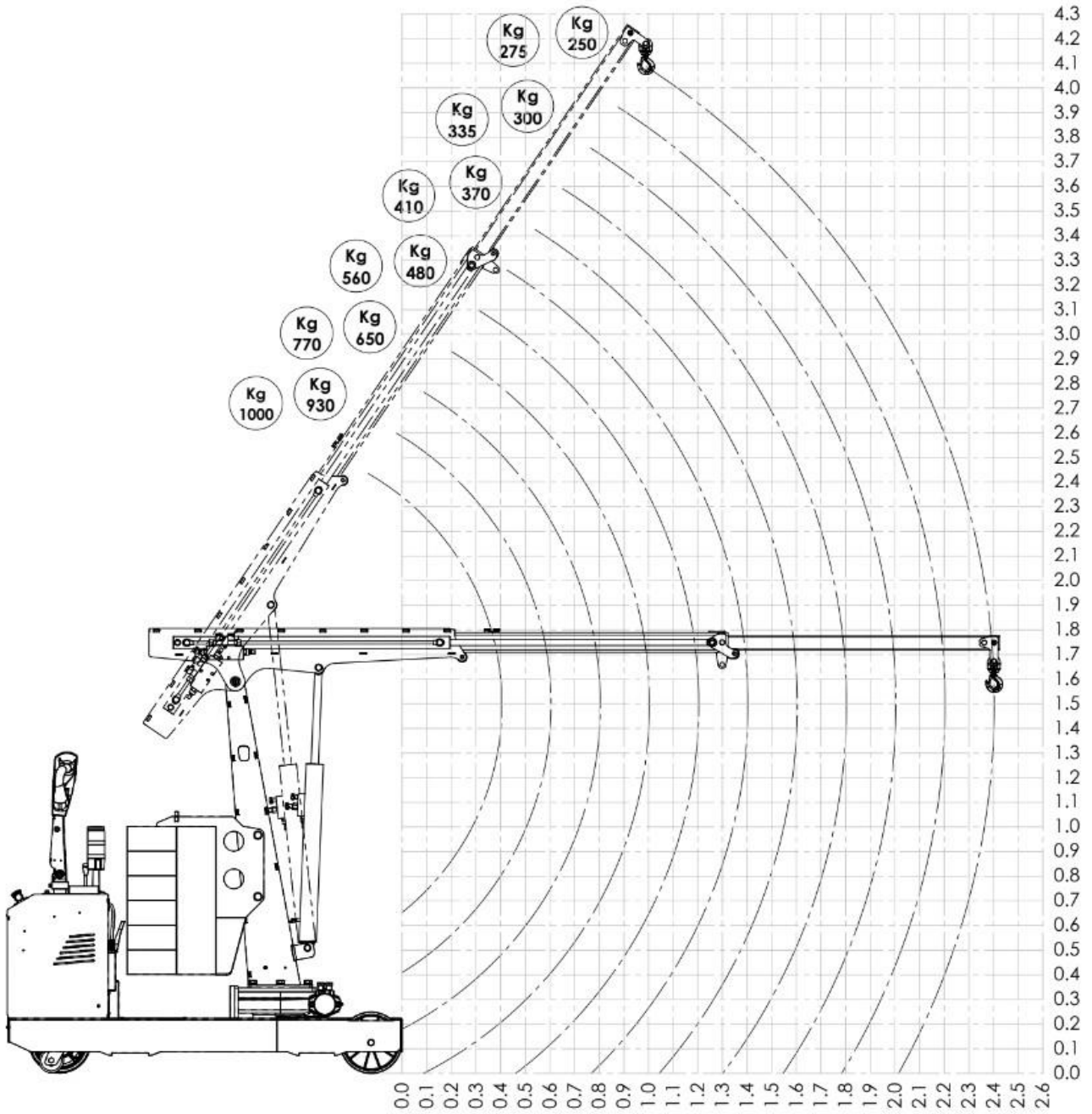

CRANE FLEX G1000DBR

LIFTING CAPACITY 1000 KG

MOTORISED COUNTERBALANCED SWIVEL CRANE

ELECTRIC LIFT/LOWER/EXTEND/RETRACT/ROTATION THROUGH RADIO CONTROL WITH PROPORTIONAL JOYSTICK



Model		FLEX G1000DBR
Drive		Electric
Rotation		220° electric controlled
Arm lifting		Electric – remote control
Arm lowering		Electric – remote control
Arm extension		Electric – remote control
Width with arm not rotated	mm/inch.	990 / 39
Width with arm rotated at 90°	mm/inch.	1120 / 44
Width with arm rotated at 90° and upgrade to optional compact ballast	mm/inch.	990 / 39 * see drawing below
Max capacity with standard double boom	Kg / lbs.	1000 / 2204 * see load chart below
Weight of the crane (counterweight incl.)	Kg / lbs.	1580 / 3483
Battery type standard		Maintenance free AGM
Batteries nos.	pcs	2
Battery voltage / nominal capacity	V / Ah	12 / 120
Lifting motor	W	800
Traction motor	W	1000

CRANE FLEX G1000DBR MAIN DIMENSIONS

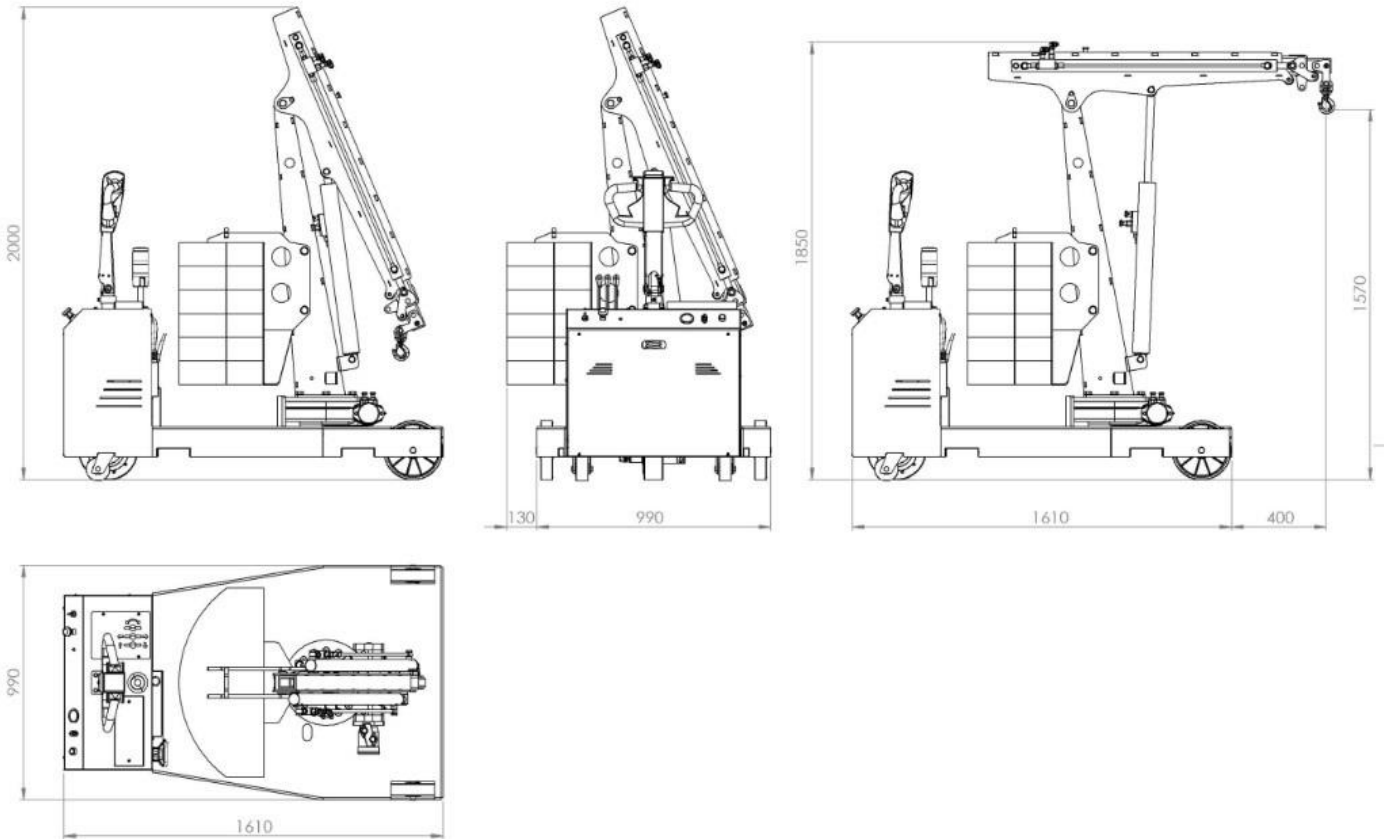

**CRANE FLEX G1000DBR
WIDTH WITH COMPACT BALLAST
PB_FLEX G1000DB**

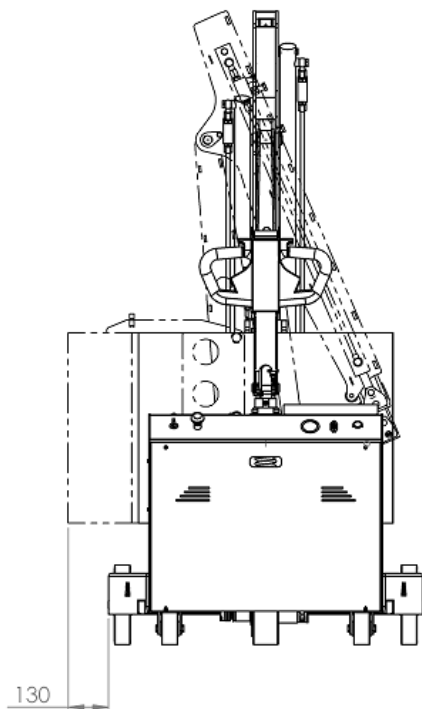
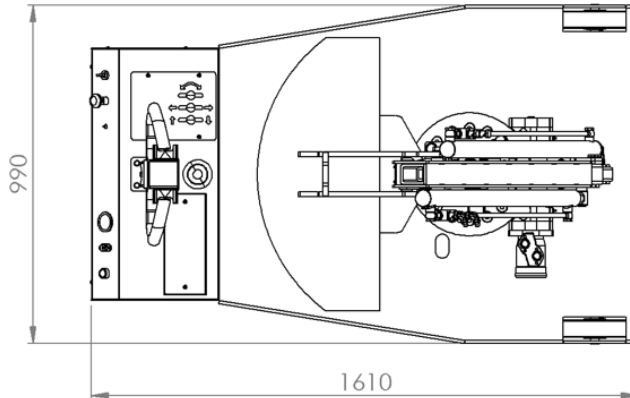

WITH STANDARD BALLAST:
WHEN THE ARM IS ROTATED AT 90°
THE BALLAST **EXCEEDS** THE CRANE
WIDTH BY 130 MM

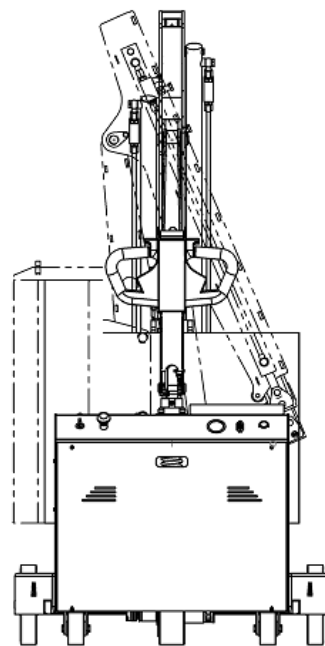

**UPGRADE TO COMPACT BALLAST
(CODE PB_FLEX G1000DB)**
WHEN THE ARM IS ROTATED AT 90° THE
BALLAST **DOESN'T EXCEED** THE CRANE
WIDTH OF 990 MM

CRANE FLEX G1000DBR DETAILED DIMENSIONS WITH STANDARD ELECTRIC TELESCOPIC DOUBLE BOOM FULLY RETRACTED

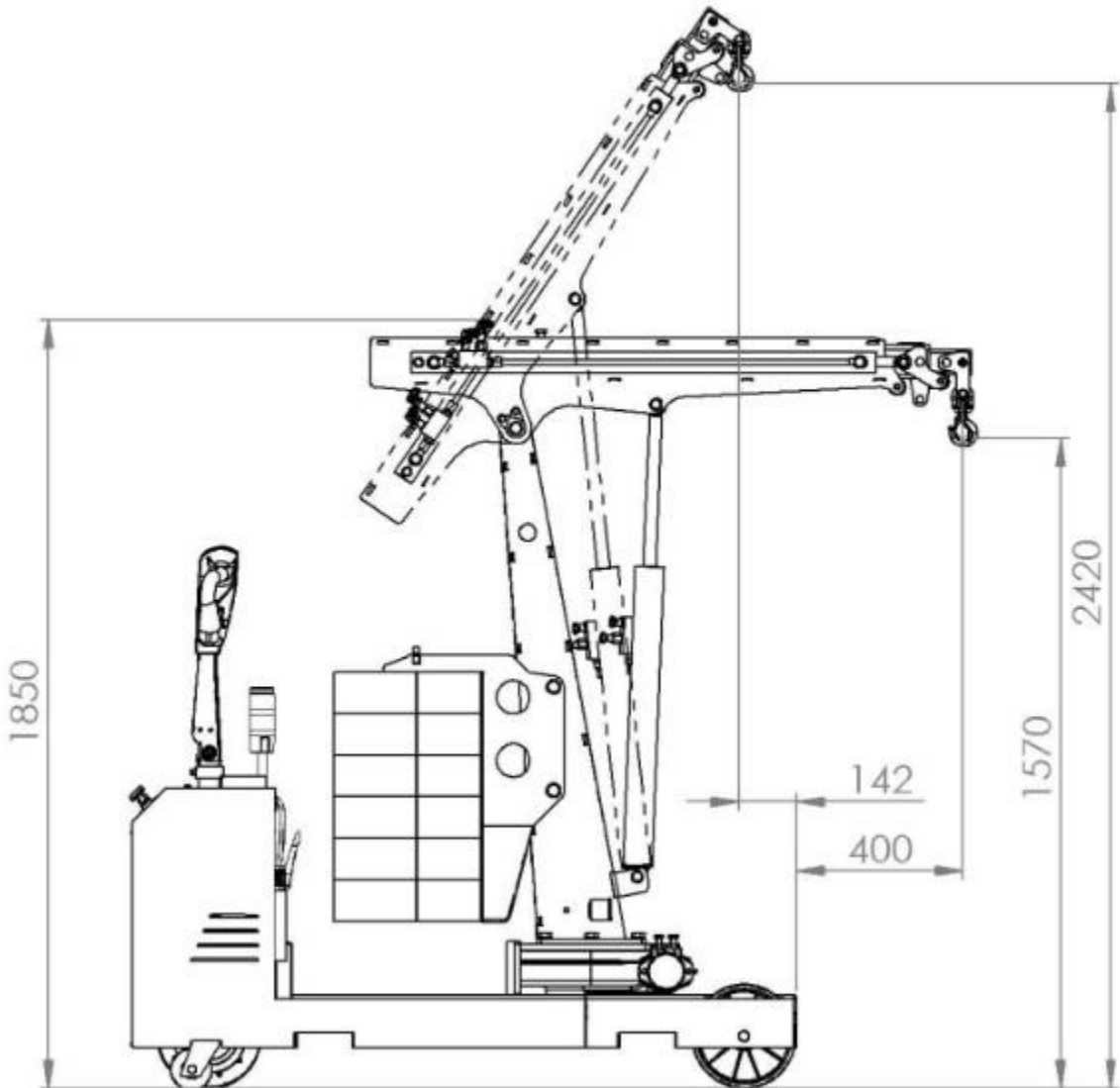

CRANE FLEX G1000DBR DETAILED DIMENSIONS WITH STANDARD ELECTRIC TELESCOPIC DOUBLE BOOM FULLY EXTENDED

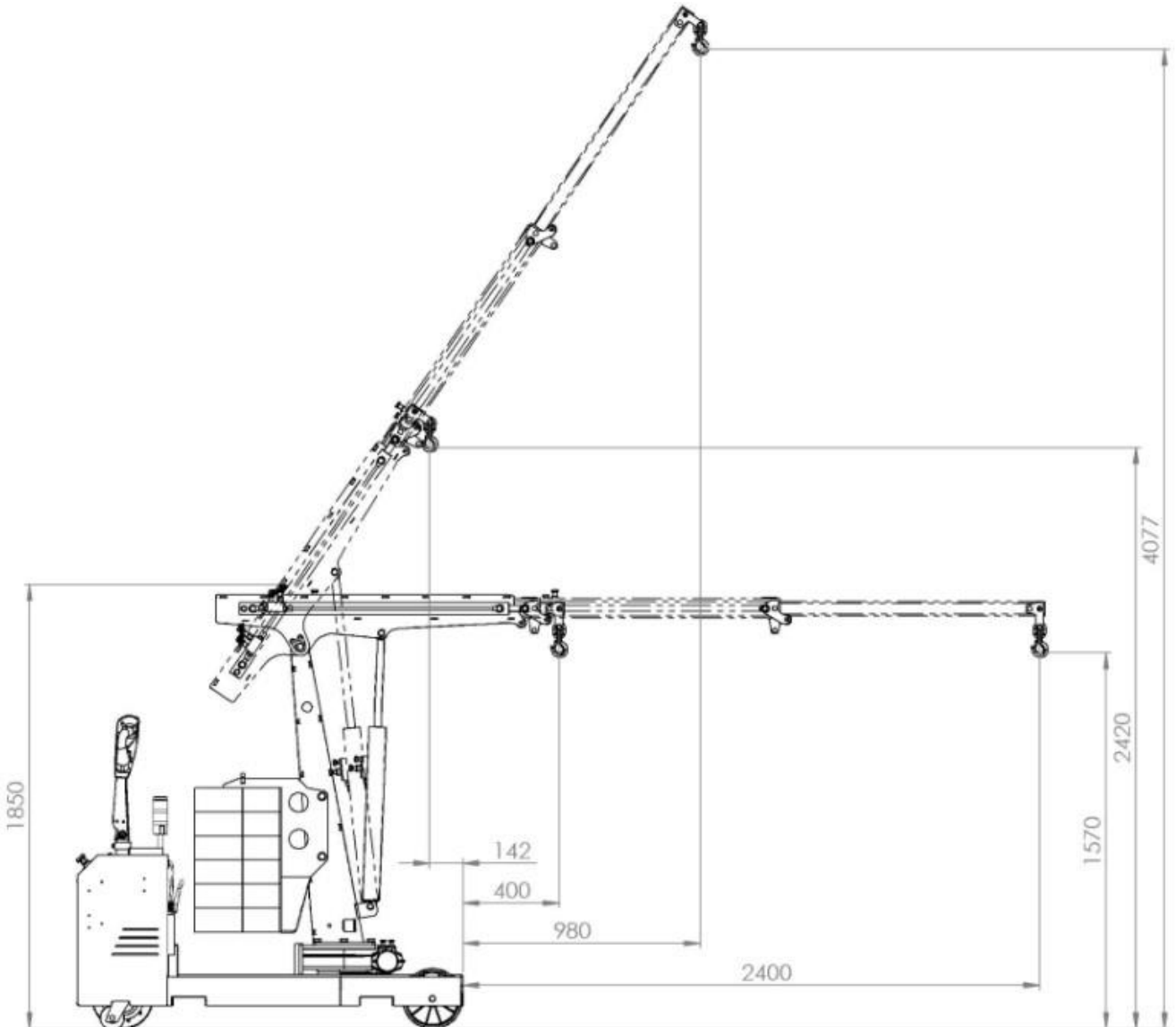

CRANE FLEX G1000DBR MAIN DIMENSIONS

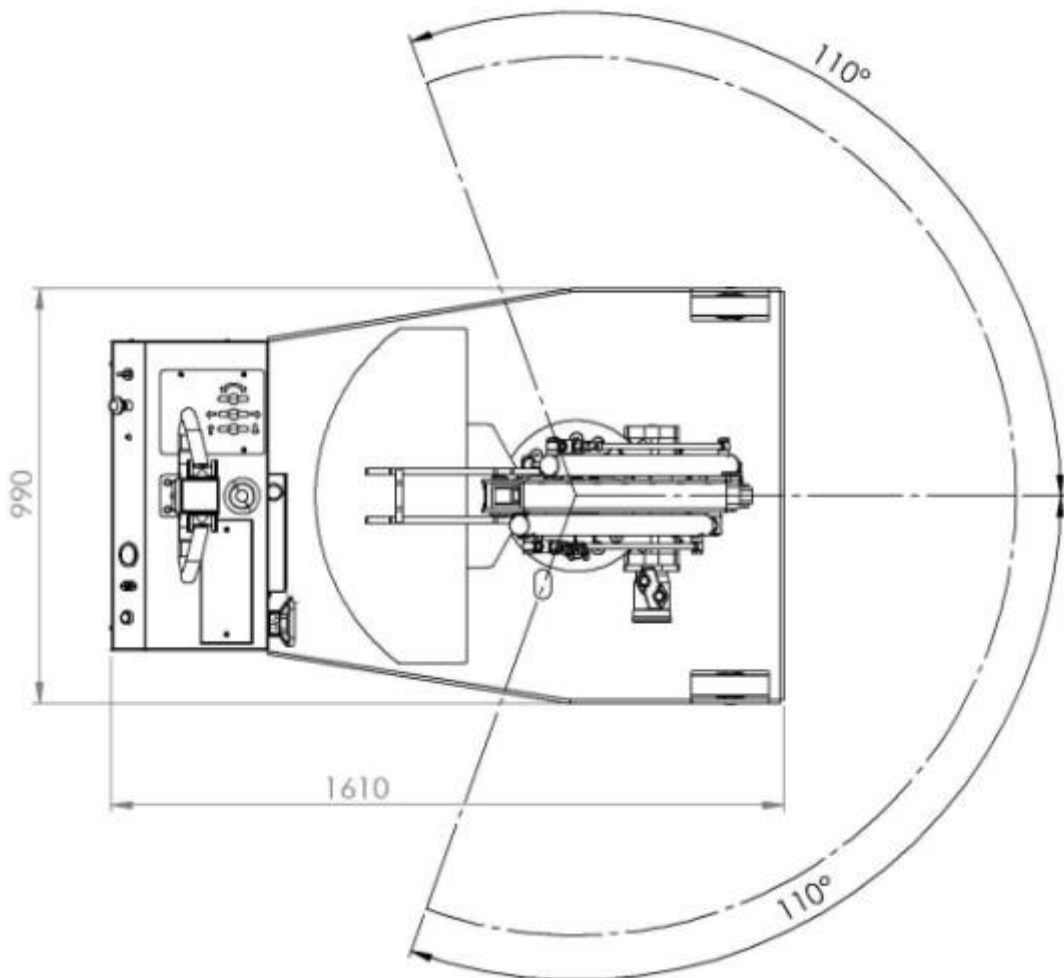

CRANE FLEX G1000DBR LOAD CHART WITH STANDARD ELECTRIC TELESCOPIC DOUBLE BOOM

